

ESTIMATES COMMITTEE

1957-58

SIXTEENTH REPORT

(SECOND LOK SABHA)

MINISTRY OF EDUCATION AND SCIENTIFIC RESEARCH

1. NATIONAL ARCHIVES OF INDIA
2. DEPARTMENTS OF ARCHAEOLOGY AND ANTHROPOLOGY
3. MUSEUMS
4. NATIONAL GALLERY OF MODERN ART
5. NATIONAL LIBRARY, CALCUTTA.



LOK SABHA SECRETARIAT
NEW DELHI
April, 1958

Price Re. 1-20 n.P.

C_O_R_R_I_G_E_N_D_A

SIXTEENTH REPORT OF THE ESTIMATES COMMITTEE ON
THE MINISTRY OF EDUCATION AND SCIENTIFIC RESEARCH
--NATIONAL ARCHIVES OF INDIA, DEPARTMENTS OF
ARCHAEOLOGY AND ANTHROPOLOGY, MUSEUMS, NATIONAL
GALLERY OF MODERN ART, NATIONAL LIBRARY, CALCUTTA.

- Page 6, Para 13, line 25; for "sulphur dixode"
read "sulphur dioxide"
- Page 7, Para 14, line 2; for "or" read "on"
- Page 7, Para 14, line 9; for "two, fold" read
"two fold"
- Page 8, Para 18, line 24; for "outsides" read
"outsiders"
- Page 34, Para 99, line 2; for "vitit" read
"visit"
- Page 44, below Appendix II; for "(Vide para 5)"
read "(Vide para 15)"
- Page 52, Appendix IV, Serial No. 1, Col. 3;
for "500-25-500-40-1000" read
"500-25-600-40-1000"
- Page 53, last line; insert "30" against
"Temporary"
- Page 75, Serial No. 4, col. 3, line 8; for
"pursuaded" read "persuaded"
- Page 82, Serial No. 46, col. 3, line 2; delete
the word "is" between the words
"learn" and "that"
- Page 85, Serial No. 62, col. 3, line 3; for
"Anthropology" read "Anthropology"
- Page 89, Serial No. 88, col. 3, line 5; for
"nnd" read "and"

CONTENTS

	PAGES
Composition	iv
Introduction	v
I. NATIONAL ARCHIVES OF INDIA	1—12
A. Introduction	1
B. Organisation	1-2
C. Functions	2
D. Activities	2—9
(a) Acquisition	2-3
(b) Maintenance of Records etc.	3-4
(c) Research and Reference	4—6
(d) Repair and Rehabilitation	6-7
(e) Microfilming and Photo-duplication	7
(f) Publications	7-8
(g) Training in Archives Science	8
(h) History of Freedom Movement in India	8-9
E. Staff	9-10
F. Finance and Accounts	10
G. Office Accommodation	10-11
H. Regional Record Offices	11
I. Miscellaneous	11-12
II. DEPARTMENT OF ARCHAEOLOGY	13—21
A. Introduction	13-14
B. Organisation	14
C. Functions	14-15
D. Activities	15—18
(a) Conservation of Monuments	15-16
(b) Explorations and Excavations	16-17
(c) Museums	17
(d) Publications	18
E. Training	18-19
F. Staff	19
G. Budget and Finance	19-20
H. Miscellaneous	20-21
III. DEPARTMENT OF ANTHROPOLOGY	22—25
A. Historical Background	22
B. Organisation and Functions	22
C. Activities of the Regional Research Stations	22-23
D. Training and Research	23

(ii)

	PAGES
E. Personnel	23-24
F. Publications	24-25
IV. MUSEUMS	26—35
A. The National Museum of India	26—30
(a) Historical Background	26
(b) Organisation	27
(c) Scope and Functions	27-28
(d) Personnel	28-29
(e) Activities	29-30
(f) Budget and Finances	30
B. Central Asian Antiquities Museum	30—32
(a) Introduction	30-31
(b) Scope and Functions	31
(c) Collections	31
(d) Library	31
(e) Educational Services	31
(f) Research	31
(g) Laboratory	31-32
(h) Future of the Central Asian Antiquities Museum	32
C. Indian Museum, Calcutta	32—34
D. General	34-35
V. NATIONAL GALLERY OF MODERN ART	36-37
A. Historical Background	36
B. Organisation and Functions	36
C. Collections	36
D. Educational Services	36
E. Personnel	37
F. Air-conditioning of Accommodation occupied by the National Gallery	37
VI. NATIONAL LIBRARY, CALCUTTA	38—41
A. History	38
B. Management	38
C. Functions	38
D. Reorganisation	39-40
E. General Activities	40
F. Second Five Year Plan	40-41
APPENDICES—	
I. Statement showing the details of the various Branches in each division of the National Archives of India and the work done therein	42-43
II. Statement showing the details of activities of the N.A.I. under Publications	44—47
III. Statement showing the strength of officers and staff of the National Archives of India in the various categories along with their respective scales of pay	48—51

(iii)

IV.	Statement showing the strength of officers and staff of the Regional Records Office, Bhopal together with their respective scales of pay	52-53
V.	Statement showing the organisational set up of the Department of Archaeology	54-56
VI.	Statement showing the sanctioned strength of officers and staff in the various categories employed in the Department of Archaeology in 1956-57 and 1957-58 together with their respective scales of pay	57-62
VII.	Organisational set up of the Department of Anthropology	63
VIII.	Note giving in brief the details of work done by the three Regional Research Stations of the Department of Anthropology during 1954-55, 1955-56 and 1956-57	64-65
IX.	List of Museums in India	66-69
X.	Organisational set up of the National Museum	70
XI.	Statement showing details of the Budget Estimates and actual expenditure of the National Museum	71
XII.	Organisational chart of the Indian Museum	72
XIII.	Organisational chart of the National Library, Calcutta	73
XIV.	A brief resume of the important activities of the National Library	74
XV.	Statement showing the summary of conclusions/recommendations	75-90

MEMBERS OF THE ESTIMATES COMMITTEE
1957-58

1. Shri Balvantray Gopaljee Mehta—*Chairman*
2. Shri S.A. Dange
3. Shri Jogendra Singh
4. Shri Mahavir Tyagi
5. Shri Satyendra Narayan Sinha
6. Shri Radha Charan Sharma
7. Shri Ranbir Singh Chaudhuri
8. Shri Gopalrao Khedkar
9. Shrimati Sucheta Kripalani
10. Shri R.R. Morarka
11. Shri M. Thirumala Rao
12. Shri J. Rameshwar Rao
13. Shri C.R. Narasimhan
14. Shri Amjad Ali
15. Shri R. Ramanathan Chettiar
- *16. Shri Ahmed Mohiuddin
17. Shrimati Renuka Ray
18. Shri Uma Charan Patnaik
19. Shri Raghbir Sahai
20. Pandit Dwarka Nath Tiwary
21. Shri Govind Malaviya
22. Shri R.L. Jangde
23. Shri N.C. Kasliwal
24. Shri Dodda Thimmaiah
25. Shri M.L. Dwivedi
26. Shri A.E.T. Barrow
27. Shri V.P. Nayar
28. Shri R.K. Khadilkar
29. Shri B.K. Gaikwad
30. Shri Shraddhakar Supakar

SECRETARIAT

Shri S.L. Shakhder—*Joint Secretary*
Shri H.N. Trivedi—*Deputy Secretary*
Shri R.P. Kaushik—*Under Secretary*

*Ceased to be a member of the Committee with effect from the 2nd April, 1958.

INTRODUCTION

I, the Chairman, Estimates Committee having been authorised by the Committee to submit the Report on their behalf present this Sixteenth Report, on the Ministry of Education and Scientific Research on National Archives of India, Departments of Archaeology and Anthropology, Museums, National Gallery of Modern Art and National Library, Calcutta.

2. The Committee wish to express their thanks to the Officers of the Ministry of Education and Scientific Research for placing before them the material and information that they wanted in connection with the examination of the estimates.

NEW DELHI ;
The 7th April, 1958.

BALVANTRAY G. MEHTA,
Chairman,
Estimates Committee.

I. NATIONAL ARCHIVES OF INDIA

A. Introduction

The National Archives of India which is the repository of the non-current records of the Government of India was set up in 1891 at Calcutta under the name of the Imperial Record Department. After the transfer of the Capital from Calcutta to New Delhi in 1911, the records of the Government were also gradually transferred to New Delhi between the years 1926 and 1937. In 1947 the Department was renamed as the National Archives of India.

The deliberations of the Indian Historical Records Commission, constituted in 1919 have made a great contribution in making this institution a fountain of accumulated experience in the field of archival administration, disseminating useful information to records institutions in the country maintained by the State Governments or built up by private bodies. It provides free access to scholars to explore the wealth treasured in its vaults, out of which the past history of the country has been written. It contains assortment of political letters, memoranda, treaties, engagements, covenants, *sanadas*, *dastaks*, diaries, military despatches etc.

B. Organisation

2. The National Archives of India is a subordinate office of the Ministry of Education and Scientific Research. The head of the Department is the Director of Archives. He is assisted by a Deputy Director, a number of Assistant Directors and other necessary staff. The technical work of the Department is divided into four main Divisions, each under an Assistant Director of Archives. The Divisions are (i) Preservation, (ii) Records and Research (iii) Publications, and (iv) Persian Records. *The Committee are of opinion that it is not necessary to have any division on the basis of language.* The administrative work is done in the Administration Division under the Administrative Officer. The details of the various Branches in each Division and the work done therein are given at Appendix I.

The Department has also a Regional Records Office at Bhopal. The head of the office there is the Keeper of Records who is of the status of an Assistant Director. Several *ex-princely* States have valuable old records of considerable historical value. *The Committee, therefore, note with surprise that only Bhopal should have been singled out for starting a Regional Records Office.*

The Director of Archives is the *ex-officio* Secretary of the Indian Historical Records Commission which is a non-official advisory body

to advise the Government of India on matters connected with Archives and allied subjects. He is also the Chairman and Convener of the National Committee of Archivists.

C. Functions

3. National Archives of India is the principal record repository of the Government of India. All non-current records of historical, administrative, legal or research value to be permanently preserved are transferred to it by all the Central Government record creating agencies. The Department is responsible for custody, preservation and service of the records transferred.

D. Activities

(a) Acquisition

4. The procedure normally followed for the acquisition of archives and historical manuscripts is that the archives and historical manuscripts of Indian interest are at first located by contacting the private owners and auctioneers. The owners are located with the help of the data periodically supplied by the Regional Records Survey Committees which have been set up by most of the State Governments or information available in articles published in journals, proceedings and bulletins of learned societies, notices in newspapers and catalogues of documentary exhibitions, etc.

Since many historical documents and family papers can still be found in England, the National Archives of India has made arrangements with English manuscripts sellers for the regular supply of catalogues to this Department to enable it to make its choice. Orders are placed for selected items through the High Commissioner for India in England.

5. The Committee understand that the Regional Survey Committees report on private collection of the manuscripts in the form of annual reports and the information gathered from such reports is collected together in the proceedings of the Indian Historical Records Commission. On that basis a list of persons who are known to possess valuable documents is prepared and the persons are contacted individually from time to time for the acquisition of the manuscripts. Attempt is first made by the Department to induce the owners to make over their collections to the National Archives of India as gifts. If the attempt fails, the owners are then persuaded where possible to part with their collections for a price. Before a purchase is made, the manuscripts are examined carefully by the Director of Archives with a view to establishing their authenticity and value to research. *The Committee suggest that an Advisory Committee consisting of non-officials may be formed to advise the Director of Archives in making these purchases.*

6. So far only the States of Assam, Bihar, Bombay, Jammu and Kashmir, Kerala, Madhya Pradesh, Madras, Orissa, Uttar Pradesh

and West Bengal and the Administration of Delhi have set up Regional Records Survey Committee. *The Committee note with regret that only one Union territory should have set up a Regional Records Survey Committee. They suggest that it should be set up in each of the Union Territories. The Committee also suggest that the remaining four States should also be persuaded to set up such Committees as early as possible so that the National Archives could acquire and make use of any archives or historical manuscripts which may come to light through the efforts of those Committees.*

Many useful documents and records including valuable historical manuscripts are lying scattered in the former Indian States. It is, therefore, essential that suitable representatives interested in that subject, from the areas concerned, are associated with these Regional Survey Committees so that all such records may be collected.

7. The Committee were told that no consolidated list of individuals, families and institutions having valuable manuscripts in their possession had been published so far. *The Committee suggest that such a list should be published for the benefit of research scholars.*

8. The Committee were given to understand that the efforts to acquire private archives had not so far been very successful. *The Committee suggest that suitable steps may be taken to evoke a better response from the parties in possession of such valuable records. A national appeal through the press might yield some result. The Regional Records Survey Committees referred to earlier would be considerably useful in this respect.*

(b) *Maintenance of Records etc.*

9. The records in the Department cover about sixteen miles of shelf space. The following figures give the quantity of records:—

	Volumes	Unbound papers
I. East India Company's Documents	28,611	16,30,000
II. Secretarial records from 1860 onwards	38,114	24,09,000
III. Foreign and Political Department Records from 1860	992	5,14,000
IV. Residency Records]	38,908	5,60,000
TOTAL	1,03,625	51,13,000

As the number of unbound papers is enormous, the Committee suggest that a systematic programme for binding should be undertaken by the Department, and a target date fixed for the completion of this work. The total number of non-archival manuscripts is about 1,900 of which 1,200 are in Persian, Arabic or Urdu. Of the rest, 553 are in English, 158 in Sanskrit, 276 in Marathi and the remaining are in other languages. Such non-archival manuscripts are lying scattered

all over the country in the various museums, research institutes, bhandars, etc. They also include manuscripts written on palm leaves, Bhrigu Samhitas, rare manuscripts on astrology and astronomy etc. etc. *The Committee suggest that a Central organisation on the same lines as the National Archives, should be set up to collect and take charge of such valuable non-archival manuscripts. This organisation will also be responsible for proper classification, preservation and cataloguing of such manuscripts as well as for the publication of suitable documents therefrom.*

This will also provide suitable facilities to the research scholars to delve into such material collected for purposes of research.

The total number of maps in the Department is as follows:—

1. Survey of India Ms. Maps	11,500
2. Printed Maps	4,150

The total number of documents requisitioned by the various Ministries and Departments of the Government of India from January, 1937 to the end of June, 1957 comes to about 6,64,000. The annual average figure for requisitions varies from 47,000 to 49,000. *The Committee regret to learn that a file issued by the National Archives of India in 1926 is still outstanding and that it had not been possible to trace the document so far. They also regret to learn that no registers of the files issued are available for the period prior to November, 1956. The Committee suggest that the circumstances leading to this state of negligence should be investigated and responsibility fixed to avoid recurrence. They also suggest that steps should be taken to make out a list of all National Archives and also to regain custody of them.*

10. The Committee were informed that the records in the National Archives of India were those which were sent by the various record creating agencies for permanent retention and the question of weeding out records in the National Archives of India did not, therefore, arise. The Committee feel that with the passage of years some of the records which were originally intended for permanent retention might be found to belong no longer to that category and might require weeding out. *They, therefore, suggest that a procedure of a periodical review for old records with the object of weeding them out, if they have outlived their utility might be evolved so that some of the much needed space for ever increasing records might become available.*

(c) *Research and Reference*

11. The Committee understand that until recently the term 'open' records meant the records of any Ministry of a date prior to 1902. All the Ministries of the Government of India have since

agreed to consider as 'open' all records which are not less than forty years old with the following exceptions:—

- (a) Ministry of Home Affairs' records are open upto 1916 subject to the restrictions that no records relating to Kashmir can be shown to anybody and that no excerpts can be taken from any confidential records of the post-1901 period without prior scrutiny of that Ministry.
- (b) Ministry of External Affairs' records are open upto 1935 subject to the restrictions that no records relating to the following territories which are of a later date than 1901 can be shown to any person:—

Afghanistan, Persia, Kashmir, Pakistan, Nepal, Tibet, China, Russia, Burma and Ceylon.

The Committee understand that the decisions of the Ministries of Home Affairs and External Affairs have already been given effect to and that steps are being taken to give effect to the decisions of the other Ministries in this behalf and that the Research Rules are being recast. *The Committee hope that the work of recasting the Research Rules will be expedited. The Committee suggest that the rules regarding the availability of records should be liberalised and all records pertaining to the pre-Independence era should be declared as 'open' some authority being retained for making exceptions.*

12. The Department has a scheme under which six fellowships of Rs. 150 per month each are awarded to six post-graduate candidates of Indian universities for research on modern Indian History. The fellowships are tenable for one year, but are renewable for another year. The fellowships are advertised in the principal newspapers and prescribed application forms are also sent to all universities in India and each university is asked to recommend the names of three candidates. For the purpose of making selection, the universities have been divided into six zones and one candidate is selected from each of the six zones. The selected candidates are the best students from each zone irrespective of the university to which they belong. The ultimate selection is made by a Committee consisting of the Secretary to the Government of India in the Ministry of Education and the Director of Archives.

The fellowship holders undertake research among the records in the custody of the National Archives of India and write a thesis for the Ph. D. or D. Phill. degree of the university concerned. The subject of research in each case is expected to be selected by the Director of Archives in consultation with the Head of the Department of History of the university concerned. The university sponsoring a scholar for the scheme is expected to print and publish at its own cost the thesis submitted to it by the candidate, within three years from the date of its acceptance for the Ph. D. or D. Phill. degree of the university. *The Committee suggest that this time lag in printing and publication should be reduced from three years to one year.*

The Committee suggest that suitable non-officials may be associated with the Committee for the final selection of candidates for the award of fellowships. As regards the selection of subjects for research, the Committee suggest that as far as possible the subject of research should be intimately connected with the material treasured in the National Archives.

The Committee learnt with regret that so far there had not been proper co-ordination between the records and research work, and that there were no definite arrangements for getting the manuscripts or the thesis of scholars published. *The Committee suggest that steps should be taken to improve co-ordination between the records and the research work and to make suitable arrangements for the publication of theses produced by scholars.*

(d) *Repair and Rehabilitation*

13. The Department, besides the normal rehabilitation programme in regard to Central Government records etc. renders repair service to outside agencies and individuals.

The Sub-Committee of the Estimates Committee that paid a visit to the National Archives learnt that a hydraulic press which had been purchased for the National Archives of India from the U.S.A. in 1948-49 started functioning only since February, 1956. The Ministry of Education who were asked to furnish reasons for the functioning of the press after about six years of its receipt have stated as follows:—

The hydraulic press was received in this Department in 1949 and installed in September, 1950. When the equipment was tested, it was observed that the steam output of the electrode boiler, which was acquired for working the press and the vacuum fumigating machine, on the advice of the specialists in the U.S.A. working in this line, was inadequate. It was at once decided to go in for another boiler. When an indent for an oil-fired boiler of the required specification was being finalized, it was pointed out that the oilfired boiler with its chimney which would give out smoke so near the Central Vista was not desirable from the aesthetic point of view. From the point of preservation of records also, it was considered undesirable to have any source of smoke, sulphur dioxide or fire risk in the Archives if those could be avoided. Electrode Boiler offered the best solution and only on an assurance of the Central Public Works Department (in December, 1952) that it would be possible for them to make sufficient amount of electricity available for working the boiler very soon, the original indent for an oilfired boiler was cancelled. It has been necessary to revise it again as the New Delhi Municipal Committee could

not keep up the assurance (on 11th June, 1953) of adequate power supply and the indent for the oilfired boiler was revived. The sanction of the Ministry of Education for its purchase was received in December, 1953 and an emergent indent for the oilfired boiler placed immediately. The boiler was supplied in August, 1955 and installed in February, 1956.

The Committee do not consider the above explanation as satisfactory and observe with regret that if sufficient care and interest had been taken in the matter and if timely advice had been obtained from the experts in the field, this abnormal delay in the functioning of the press could have been avoided.

(e) *Microfilming and Photo-duplication*

14. The Committee understand that there is a scheme to supply free or quasi permanent loan, microfilm copies of rare manuscripts to the following four institutions:—

1. Bhandarkar Oriental Research Institute, Poona.
2. The Adyar Library, Madras.
3. The Calcutta University Library, Calcutta.
4. Maharaja Sayaji Rao Oriental Research Institute, Baroda.

The scheme was first mooted in 1952 at the suggestion of the Prime Minister and has two fold objects viz., (a) to provide wider access to scholars and (b) to ensure preservation. *The Committee welcome the scheme and also suggest that the advisability of gradually extending it to other institutions and to wider ranges of important records should be examined.*

(f) *Publications*

15. The details of activities under publications are given at Appendix II.

The Committee were informed that 500 copies of each publication brought out by the National Archives of India were printed and it was now intended to print 750 copies of all publications. *The Committee suggest that a larger number of copies should be printed as these publications are of high research value based on authentic records and will be useful to the various libraries and research institutions in the country. The Committee suggest that the distribution list of these publications should be suitably revised to ensure that maximum benefit is derived by as many agencies as possible. All the libraries of the universities, colleges and districts should be included in the list.*

16. The Committee understand that a scheme for the compilation of a National Register of Records and Historical Manuscripts was drawn up by the Research and Publication Committee in July, 1947. Towards the end of 1956, it was decided to limit the scope

of the scheme to records in private custody due to the enormous cost involved. It was stated before the Committee that though the work undoubtedly was important, it should primarily be the concern of the State Governments. The Committee would like to observe that there is a possibility of the work being neglected if it was left entirely to the State Governments. *The Committee would, therefore, suggest that if a scheme on the lines of the History of Freedom Movement in India and the Revision of the Gazeteers is formulated and the Central Government promise to the State Governments a substantial grant-in-aid to prepare the scheme, it is likely that the States may carry it out under the general guidance and supervision of the Central Government. A Central Committee and state Committees may be established for the scheme which may be spread over a number of years, depending on the availability of funds for the purpose.*

17. *The Committee suggest that the National Archives should formulate a scheme for publishing extracts of important documents on connected subjects, giving facts, history etc., about a particular development.*

(g) *Training in Archives Science*

18. The Department has a scheme of training in archives science. Two training courses viz., (i) one year's Diploma Course and (ii) three months' short course of training in Archives Keeping, are conducted by the National Archives of India. While the former is open to Government employees as well as the general public, the latter is restricted to Central and State Government employees only. *The Committee suggest that the latter course may also be thrown open to the general public. Two stipends each of Rs. 125 per month are awarded to two trainees in one year's Diploma course on merit. The selection is made by holding a written test after two months of their joining the training course. The Committee suggest that the written test should be held at the time of joining and not two months after. The Committee were informed that about 8 to 10 candidates were taken for training per year. They also learnt that no follow up figures of outsiders who were taken as trainees had been kept. The Committee consider that it would be worthwhile having a regular scheme for training, something like a training school for which there should be proper publicity and to which even non-Government employees may be admitted. The trainee should, on the completion of the course be awarded a diploma or certificate. The Committee also suggest that the number of trainees should be larger than at present in order to meet the needs of Government offices and non-official bodies. They further suggest that follow up information about outsiders who have taken the training should be maintained.*

(h) *History of Freedom Movement in India*

19. *The scheme for writing an authentic and comprehensive history of the different phases of the struggle which culminated in the*

freedom of India on the 15th August, 1947 was originally recommended by the Indian Historical Records Commission at its Jaipur Session in 1948. Subsequently an experts' Committee of distinguished scholars of Indian History was appointed to suggest ways and means for facilitating the collection of material for this history. In pursuance of the recommendations of the experts' Committee, the Government of India constituted a Board of Editors, History of Freedom Movement in the year 1952 for the compilation of the History of Freedom Movement in India. During their three years' term, the Board collected material comprising of 1389 items involving 53,837 pages.

After the dissolution of the Board on the 31st December, 1955, the work of collection of further material was entrusted to the National Archives of India. Steps were taken by the Department to complete the catalogues by incorporating the items which were listed by the Board. Attempts were also made by the Department to fill in as far as possible the gaps in the material sent by the different States. In all, the National Archives of India collected material on 1,507 items involving 79,490 pages. The entire material collected has since been catalogued. *The Committee suggest that a classified catalogue of the material collected should be published so that it could be made use of by scholars and historians.*

20. The Committee were informed that Dr. Tara Chand had been appointed Narrator to write the History. *The Committee suggest that it would be of advantage if a Committee of advisers was appointed to assist the Narrator. The Committee of Advisers may consist of persons who were associated with the Freedom Movement and who know the various phases of the Movement. The Committee are of the view that the work relating to the History of Freedom Movement has already been considerably delayed and should be expedited as much as possible.*

21. *The Committee understand that the material collected for writing the History of Freedom Movement by the Board of Editors is so voluminous that it may not be possible to publish a substantial portion of it. The Committee, however, suggest that suitable selections from the material should be properly documented and published.*

E. Staff

22. A statement showing the strength of officers and staff of the National Archives of India in the various categories together with their respective scales of pay is placed at Appendix III.

A similar statement in respect of the Regional Records Office, Bhopal is placed at Appendix IV.

23. The Committee were informed that being a specialised field, it was difficult to get men with adequate experience and training for the National Archives. The policy followed is to select candidates with the desired educational qualifications for various categories of

posts and then let them gain knowledge of Archival Science in the course of their work in this Department. The Committee were informed that training facilities in the Department were on the whole adequate but it was felt that training in up-to-date methods in countries with a long experience of archives science would be of advantage. Hence, an officer of the Department had recently been sent abroad for training in the latest scientific methods of repair and binding. *This Officer, on return, should be able to train the staff and help in setting up the suggested training school.*

The Committee observe that there is almost a stream of people going abroad one after the other to learn one thing or other and that there appears to be no systematic policy in this regard. The Committee consider that if it is necessary to get more up-to-date training abroad, a regular scheme should be drawn up according to which the best available persons in the country should be selected and sent abroad for training. The Committee suggest that having deputed some body for training abroad, on his return, he should be asked to impart his training to many others in the country by conducting a class or a course so that it might not be necessary every time to send some body or other for the same training. The Committee further suggest that the persons trained abroad should then try to keep themselves in touch with whatever is happening outside by way of exchange of literature etc. The Committee are of the opinion that some such arrangement will eventually lead to self-Sufficiency in technical personnel in this field.

F. Finance and Accounts

24. The following statement shows the actual expenditure on National Archives of India during 1954-55, 1955-56 and 1956-57 and the Budget Estimates for 1957-58:—

<i>Year</i>	<i>Actual Expenditure</i>
	Rs.
1954-55	6.89,884
1955-56	7.11,799
1956-57	8.63,968

A sum of Rs. 13,30,000 has been provided in the Budget Estimates during 1957-58 for National Archives of India. This includes a provision of Rs. 2 lakhs for Development schemes, and Rs. 75 thousand for the History of Freedom Movement.

G. Office Accommodation

25. The National Archives of India is at present in occupation of 1,15,000 sq. ft. of accommodation. It requires an additional 1,90,000 sq. ft. of accommodation to meet its immediate demand. A provision of Rs. 55 lakhs has been made in the Second Five Year Plan for the construction of an Annexe to the National Archives of

India building. The Committee learn that the original estimate of Rs. 55 lakhs on the construction of the Annexe has since been reduced to Rs. 40 lakhs. It was stated before the Committee that it would not be desirable to shift a portion of the National Archives of India to some other city as that would not only involve duplication of expenses and construction of more rooms at the new place but would also hamper research and Government work. *The Committee are not however, convinced of the justification for spending Rs. 40 lakhs in constructing additional accommodation for the National Archives.*

H. Regional Record Offices

26. Consequent on the Government of former Bhopal State giving a free gift to the Government of India of their valuable collection of archives of national importance on the condition that they should not be shifted outside Bhopal, a branch of the National Archives of India was opened at Bhopal in 1954. This Branch known as the Regional Record Office, Bhopal has so far taken over approximately 3,00,000 files and 30,000 volumes from the late Bhopal Government. The total expenditure incurred on setting up this office (from 22.11.1954 to 30.5.1957) is Rs. 1,44,575. A provision of Rs. 86,000 has been made during 1957-58 for this office.

The Committee regret to learn that no facilities were provided in this office until recently for research scholars to consult records. The Committee were told that no facilities could be offered because there was no research room in the branch office. A room for the purpose has now been made available. *The Committee would like to stress that whenever any such record office is opened, it is important that adequate facilities for research should be simultaneously made available as otherwise an important purpose behind the opening of regional record offices is defeated.*

I. Miscellaneous

27. The Committee were informed that it was the policy of the Government of India to assume responsibility for preservation and protection of historical records of national importance wherever considered necessary. The Committee observe that due to lack of adequate resources, several State Governments are not in a position to take proper care of historical monuments and records other than those declared as of national importance. *The Committee suggest that the feasibility of transferring the item 'ancient and historical monuments and records other than those declared by or under law made by Parliament to be of national importance' from the State List to the Concurrent list of the Seventh Schedule to the Constitution of India may be examined.*

28. *The Committee are of the view that it would be desirable to have five Regional Archives, one each in the South, North, East, West and in the Centre of the country, so as to cater to the needs of*

the various parts of the country. They suggest that the advisability of formulating such a plan now although it may take some time to materialise may be examined. The Committee would also suggest that some palaces of the former princes which might be available could perhaps be used for the proposed Archives.

29. The Committee also suggest that in addition to the National and proposed Regional Archives, some of the universities, libraries or museums might also be developed as second or third grade archives.

II. DEPARTMENT OF ARCHAEOLOGY

A. Introduction

30. The archaeological studies in India had an humble beginning in the efforts of an enthusiastic band of antiquarians, who, ably guided by Sir William Jones, formed, in 1784, under the name of the Asiatic Society, an institution for enquiring, among other things, 'into the History.....the Antiquities, Arts, Sciences and Literatures of Asia'.

The first Archaeological Survey of India came into existence in 1861. After four decades of vacillation in plan and policy, the second year of the present century witnessed the resuscitation of the Archaeological Survey of India in a new form and with the clear-cut purpose of survey, including exploration and excavation, preservation of monuments, epigraphical research and development of museums. While the Archaeological Survey has been the main organisation of its kind in India, it has not always been ploughing its lonely furrow, for its activities have sometimes inspired and have been usefully supplemented by the efforts of sister-organisations and individuals.

In 1948, the Archaeological Survey of India was renamed the Department of Archaeology.

31. The Constitution of India makes the following allocation of functions relating to archaeology between the Union and the State Governments:—

- (i) Union: ancient and historical monuments.... and archaeological sites and remains, declared by or under law made by Parliament to be of national importance; and
- (ii) State: ancient and historical monuments....other than those declared by or under law made by Parliament to be of national importance.
- (iii) Besides these two categories, both the Union and the States would have concurrent jurisdiction over archaeological sites and remains other than those declared by Parliament by law to be of national importance.

On the recommendation of the Federal Finances Integration Committee, the Government decided that the monuments of national importance in what were called the Part B States should be, for the time being, maintained by the concerned States, the expenditure being reimbursed to them by the Centre. The responsibility for monu-

ments in the Centrally-administered Part C States was forthwith assumed by the Department of Archaeology.

In fulfilment of the provisions of the Constitution, Parliament passed in 1951 'the Ancient and Historical Monuments and Archaeological Sites and Remains (Declaration of National Importance) Act' by which all the monuments previously protected under the Ancient Monuments Preservation Act in Part A States, corresponding to the former provinces of British India, were redeclared as of national importance and about four hundred and fifty monuments and sites in Part B States were included in the national list. This Act has further been amended by the Ancient and Historical Monuments and Archaeological Sites and Remains (Declaration of National Importance) Amendment Act, 1956.

B. Organisation

32. The Union Department of Archaeology is an attached office of the Ministry of Education and Scientific Research. It is headed by the Director General of Archaeology. The Department consists of Headquarters office at New Delhi, 9 Circles offices in different parts of the country, 4 special branches and a Museum section. A chart showing the organisational set up of the Department is given at Appendix V.

The Committee were informed that the Archaeological Circles had been formed on the basis of even distribution of the work of maintenance and upkeep of monuments. These Circles were reorganised last in 1953 when monuments from Part 'B' and Part 'C' States were taken over by the Union Department of Archaeology. The Committee note that two Circles, namely, North Western Circle at New Delhi and Northern Circle at Agra are situated at close proximity. *The Committee suggest that the position regarding the existing Circles should be reviewed to see whether a more rational distribution of the existing Circles is feasible from the point of view of the work load and the area to be covered.*

C. Functions

33. The Department is the principal authority for implementing the provisions of the Ancient Monuments Preservation Act 1904 and the Ancient and Historical Monuments and Archaeological Sites and Remains (Declaration of National Importance) Act 1951 as amended by the amending Acts of 1954 and 1956. The principal functions of the Department are:—

- (i) conservation of ancient monuments;
- (ii) excavations and explorations of ancient archaeological sites;
- (iii) maintenance of Museums falling within the jurisdiction of this Department;

- (iv) epigraphy, copying, deciphering and publication of inscriptions;
- (v) publications.

D. Activities

(a) Conservation of Monuments

34. The number of monuments and sites which are protected by the Central Government is about 5,000. The Committee learnt that there was no up-to-date printed list of monuments declared as of national importance and protected by the Central Government. The Committee were, however, informed that an up-to-date manuscript list of such monuments was maintained by the Department for its own use, and that the printing of an up-to-date list had been deferred pending re-assessment, now in progress, of monuments with a view to deciding whether they should be retained as of national importance. The latter project is likely to be completed by 1959. *The Committee suggest that the Department should take steps to have the list of monuments declared as of national importance printed early. The list can then be amended from time to time, as necessary.*

35. The Committee were given to understand that the States of Uttar Pradesh, Andhra Pradesh, Mysore, Kerala, Orissa and West Bengal have passed legislation to look after such monuments in their area as are not of national importance. *The Committee would like the Ministry to take up the matter with the other States with a view to similar legislation being enacted.*

36. The conservation work in the Department is split up into two parts (i) Annual Repairs and (ii) Special Repairs.

In the case of annual repairs, the works are executed departmentally. So far as special repairs are concerned, the works are executed partly through contractors and partly by the Department. It may be of interest to note that the following monuments are included in the current programme of repairs of the Department:

- (i) Jama Masjid, Delhi
- (ii) Sun Temple, Konarak
- (iii) Taj Mahal, Agra
- (iv) Chittorgarh Fort
- (v) Elephanta Caves.

The actual expenditure on the conservation of monuments during 1954-55, 1955-56 and 1956-57 is as follows:—

	(Rs. in lakhs)
1954-55	23·87
1955-56	28·40
1956-57	30·24

A provision of Rs. 35·44 lakhs has been made under this head in the budget estimates for 1957-58.

The sub-Committee of the Estimates Committees that visited Agra were sorry to note that the gardens of the Taj were in a somewhat neglected state. The Committee would like the department to pay greater attention to this unique monument of international fame.

(b) *Explorations and Excavations*

37. A provision of Rs. 8,90,000 has been made under the Second Five Year Plan for exploration work. *In view of the fact that the ground covered in this direction is as yet totally inadequate, the Committee suggest that efforts should be made to increase the provision under this head and to step up the tempo of work.* The expenditure on excavations is included in the normal budget of the Department. A statement showing the amounts provided and spent on excavation and exploration work during each of the last three years is given below:—

<i>Year</i>	<i>Budget provision</i>	<i>Actual expenditure</i>
	Rs.	Rs.
1954-55	2,55,573	2,44,212
1955-56	2,79,000	2,76,300
1956-57	5,35,900	5,04,000
1957-58	7,72,000	Not available.

38. The Committee understand that the selection of sites for excavation and allotment of priority *inter se* depends primarily on the problem in hand, and secondly, on the promise that the site may hold out of yielding clues for its solution. They further understand that the main problem in the North today is to establish links between the Indus and associated cultures and the beginning of the historical period in India. It has also been stated that the traces found of an allied chalcolithic culture in Central India and the Deccan have held out great promise of affording this much sought after link. In the light of recent evidence, new sites are being explored for excavations towards the solution of this problem. In South India, the main problem is to effect a link between the well known megalithic culture of the historical period with the earlier cultures. *The Committee suggest that instead of going into such individual problems in an isolated manner, it would be desirable to have a complete survey of all the potential sites and then to fix priorities, after full consideration of all sites. It would be useful to draw up a perspective plan for this purpose in consultation with the Central Advisory Board of Archaeology.*

39. The following are the important sites at which excavation works are now in progress:

- (i) Nagarjunakonda
- (ii) Ujjain
- (iii) Lothal

(iv) Kunnathur

(v) Jaugada

The Committee learnt that no request had so far been made by the Government of India to UNESCO for assistance for archaeological excavations in India. The Committee feel that some foreign and International organisations may be interested in Lothal, Nagarjunakonda and other such civilizations in India and it might be possible to have for these projects some International co-operation, technical knowledge and financial resources. *The Committee, therefore, suggest that the possibility of negotiating such co-operation and assistance with some international agency which might be interested in this sphere, for a wide spread programme of archaeological excavations, may be explored.*

(c) Museums

40. The Department of Archaeology has under its control the Archaeological Section, Indian Museum, Calcutta, the Central Asian Antiquities Museum and the following site museums:

- (a) Sarnath
- (b) Nalanda
- (c) Bodh Gaya
- (d) Nagarjunakonda
- (e) Hampi
- (f) Kondapur
- (g) Fort St. George
- (h) Khajuraho
- (i) Delhi Fort
- (j) Amaravati
- (k) Sanchi

The Committee suggest that some of these museums should, with advantage, be merged with the local museums. They also suggest that a site museum should be established at Lothal.

The Committee understand that a draft of the National Directory of Museums in India has been prepared and is under revision. *The Committee hope that this work will be expedited.*

41. Incidentally, the sub-Committee of the Estimates Committee that visited Sarnath noticed that a costly guest house had been constructed at Government expense by the Ministry of Transport, in connection with the Budha Jayanti Celebrations, and that this guest house was now hardly being patronised. *The Committee suggest that the matter may be examined with a view to seeing how this building can best be utilised.*

(d) *Publications*

42. The Department brings out a number of publications, important, among them, being Ancient India, Indian Archaeology—A Review, Corpus Inscriptionum Indicarum, Epigraphia Indica, picture postcards. The Ancient India and Indian Archaeology—A Review are brought out annually. While the former contains general and research articles on the different aspects of the archaeological problems of India and the adjacent countries, the latter gives the chief activities in the country in the field of archaeology each year. The Committee were informed that the price of the publication 'Corpus Inscriptionum Indicarum' was Rs. 125/- per copy and that the number of copies printed was 750. *The Committee suggest that the number of copies of this publication may be suitably increased in future and copies thereof supplied to all the Museums, Universities and other important research libraries in the country.*

43. The Committee were told that the Department of Archaeology was experiencing difficulty in regard to the printing of picture postcards. Under the existing rules, picture postcards to the extent of 2500 could be printed. It was stated that there was a large demand for them. *The Committee suggest that the number of picture postcards to be printed may be increased to meet the demand.*

44. The Committee learnt that the Department was experiencing difficulty in the procurement of art paper for its publications. *The Committee are of the view that instead of wholly relying on imported paper, the indigenous production of art paper of the requisite standard should be encouraged and suggest that the Ministry of Commerce and Industry should look into this.*

45. The Committee understand that a few handwritten and calligraphy specimens have been preserved by the Department in the Delhi Fort Museum but no list of such manuscripts has yet been published. There are 405 manuscripts in the Central Archaeological Library, out of which 103 are in Sanskrit and have been catalogued, but not published. The remaining manuscripts are Tibetan and are being catalogued. *The Committee suggest that the work of cataloguing the manuscripts should be completed and that a list of manuscripts should be published as early as possible.*

E. Training

46. The Department has a training scheme in the field of Archaeology. A limited number of candidates from the Department, Indian Universities and State Governments (including those foreign candidates whose nominations are received by the Ministry) are selected for training at the various excavation camps. No fees are charged from the trainees. The period of training is about 4 months. Before commencing excavation at places where training is to be imparted, the various universities and other bodies are informed and requested to recommend their nominees, if any, for

training. Candidates should be either first class graduates or possess a 2nd class M.A. degree in History. The average number of excavation camps held in a year is 8. The students are generally associated to receive training where excavations on a large scale are undertaken. During 1957-58, 24 students were attached to the excavation camps at different places.

It has been stated that it is not possible to meet the requirements of the various Universities in the country in respect of practical instruction in field work to students of Archaeology. *The Committee suggest that the training facilities in the Department be expanded so as to meet the requirements of the Universities.*

The Committee were informed that the Director General of Archaeology had in mind certain proposals to set up a school of Archaeology. *The Committee consider that it would be desirable to have such a school so that training could be given not only to those who are in the Department but also to others and suggest that the proposal may be finalised early. The proposed school should arrange for advanced courses in the various subjects connected with Archaeology.*

F. Staff

47. A statement showing the sanctioned strength of officers and staff in the various categories of posts employed in this Department in 1956-57 and 1957-58 together with their respective scales of pay is attached at Appendix VI.

There has been no increase in class I and Class II posts. In regard to Class III and Class IV posts, the increases are 176 posts and 158 posts respectively. The increases have been stated to be due to the various projects undertaken, in the Second Five Year Plan, Temple Survey Projects, Nagarjunakonda Excavation Project and the expansion of other conservation and excavation work. All the same, the increase seems to be rather precipitate. *The Committee suggest that the matter may be carefully examined by the O. & M. Division to see whether the increase in staff is commensurate with the increased activities undertaken.*

G. Budget and Finance

48. The figures of expenditure incurred on the Department of Archaeology during 1954-55, 1955-56 and 1956-57 are as under:—

Year	Amount of expenditure (in lakhs of Rs.)
1954-55	49.23
1955-56	58.22
1956-57	68.87

A sum of Rs. 96.93 lakhs has been provided in respect of this Department in the budget for 1957-58. The increase in the budgeted estimates has been stated to be due to the expansion of activities of the Department resulting in the increase in staff.

H. Miscellaneous

49. The Committee understand that the following universities have their Departments of Ancient Indian History and Archaeology:—

1. Calcutta
2. Patna
3. Allahabad
4. Banaras
5. Lucknow
6. Madras
7. Saugar.

50. The following institutions are engaged in archaeological research work in India.

1. Allahabad University
2. K. P. Jaiswal Research Institute, Patna
3. Deccan College & Post Graduate Research Institute Poona
4. Saugar University
5. Calcutta University
6. Banaras Hindu University.

51. The Committee understand that grants-in-aid are given to such learned societies etc. as do research work in the field of archaeology. A small provision is made every year in the budget of this Department for this purpose. The societies are invited to submit their proposals for financial assistance. During current year, grants-in-aid are being given to the Calcutta University and the Deccan College and Post Graduate Research Institute. *The Committee suggest that the question of strengthening the Departments of archaeology of the universities and of other institutions engaged in archaeological research work should be examined and proper schemes should be formulated, publicised and Universities and institutions be asked to take them up with the aid of grants.*

52. The Committee understand that the following State Governments have not yet established their own Departments although there are monuments and exploration works to be looked after there:—

- (i) Punjab
- (ii) Bihar
- (iii) West Bengal, and
- (iv) Assam.

The Committee hope that the Central Government would impress on the State Governments concerned the necessity of taking immediate steps in this direction.

53. The Headquarters office of the Department of Archaeology, the Excavation Branch, Garden Section and the Central Archaeological Library occupy 17,015 sq. ft. of accommodation in Delhi. The Committee were informed that the question of a change in the location of the Department was under consideration. *The Committee feel that there does not appear to be much justification for this Department to be in Delhi. From a broad national point of view, the Committee consider that the multifarious activities of the Government should be spread out evenly in the different parts of the country. For this reason and in order to relieve pressure on accommodation in Delhi the Committee suggest that the headquarters of the Archaeological Department should be shifted to some place outside Delhi where suitable accommodation may be available.*

III. DEPARTMENT OF ANTHROPOLOGY

A. Historical Background

54. The Department of Anthropology was separated from the Zoological Survey of India in December, 1945, and set up as an independent Department on the basis of a scheme prepared by Col. R.B.S. Sewell, F.R.S., as it was felt that India would require expert anthropological guidance for integrating her 25 million tribal population in the socio-economic-political structure of the country. This important task of proper integration requires correct scientific information about their socio-economic conditions, their languages, psychology, aptitude and personality factors, etc. The Department of Anthropology has been planned to meet these requirements by covering all the important fields of anthropological and allied research.

B. Organisation and Functions

55. The Department of Anthropology is a subordinate office of the Ministry of Education and Scientific Research and is headed by a Director. It has its Headquarters at Calcutta and three regional research stations are located as follows: (i) Assam station at Shillong, (ii) Nagpur station, and (iii) Andaman and Nicobar Station at Port Blair. A chart showing the organisational set up of the Department of Anthropology is placed as Appendix VII.

The Department of Anthropology has for its functions the study of the physical types of man as found in the large number of tribes and social groups comprised in the Indian population, their genetical constitution, their rates of growth and physiological conditions including nutrition, diet, health and serology, their psychological reactions and social attitudes, linguistic and ethnographic character. The Department sends out teams of workers comprising experts in different aspects of life to areas which are of strategic importance from the anthropological point of view, for studying particular tribes and populations in their natural environment. A comprehensive view of the population is thus obtained, supplemented by photographs, cine records, films and phonographic records of their everyday life and normal activities, religious and social ceremonies, dialects and music etc. The results from these expeditions are analysed in the Departmental Laboratories and published in Bulletins and Memoirs, besides journals of learned societies.

C. Activities of the Regional Research Stations

56. A note giving in brief details of work done by the three regional research stations of the Department during the last three years is attached as Appendix VIII.

The Committee feel that the activities of the Andaman and Nicobar station during the last three years have been rather sluggish.

The Committee suggest that priority be given to the study of tribes about whom nothing or very little is known at present and of tribes which have been gradually declining in number or are stagnant.

D. Training and Research

57. There is a training scheme in the Department of Anthropology. The training scheme was started in 1946 to give advanced training to post-graduates students in Anthropology and allied subjects, so that sufficient number of anthropologists might be trained to meet the requirements of the Department, and also with the object that administrators who have to deal with tribal population may be given proper training. 8 students are taken every alternate year. The trainees are given advanced training in Anthropometry, Craniometry, Human Biology, Social Anthropology, Ethnography, Primitive Psychology, Linguistics, Biochemistry, etc. for a period of two years. The training comprises of work both in the laboratory, and in the field. During the period of training, the students are given a stipend of Rs. 150 per mensem. The Committee understand that while no guarantee of appointment in the Department after training is given, every effort is made to absorb them in the Department itself. The Committee further understand that most of the trainees who completed training have already been absorbed in the Department. Others have joined universities, tribal research institutions, etc. The Committee learn that this Department alone is in a position to give such advanced training because it has at its disposal a wealth of pre-historical materials including skeletal remains, both human and animal, from all the important pre-historical sites in India.

The Committee were given to understand that facilities available in the Department are comprehensive and comparable to those in the foreign countries.

E. Personnel

58. The Committee regret to note that in spite of the fact that the Department has been running a scheme of advanced training since 1946, it has not been able to meet its requirements of technical staff in full. It has been stated that it is expected that the inadequacy of trained staff will not stand in the way of implementation of the schemes, though the progress of work may be retarded to a certain extent. The Committee consider this rather unsatisfactory. *The Committee fail to understand why this shortage of trained staff should persist. They suggest that the matter should be carefully investigated to see whether the personnel trained by the Department, and particularly those who were given stipends are serving in the Department or whether they have been allowed to join other services.*

They also suggest that requirements of the technical personnel during the Second and Third Plans should be properly assessed and steps taken to train up the required number of personnel. There should be no difficulty in this regard, specially because it has been claimed that the facilities available in the Department for training and research are comprehensive.

F. Publications

59. The Department brings out bulletins, memoirs, study notes and papers dealing with the different aspects of the cultural and physical anthropology of tribes or communities in different parts of India. The Committee are glad to learn that these publications are distributed in the various countries on an exchange basis. This keeps the Department in touch with the latest techniques and processes in the field of anthropology. The Committee suggest that all Universities, colleges, important Libraries and such other Institutions should be on the mailing list.

The Committee, however, learn that separate annual reports dealing exclusively with the Department are not issued. The Committee suggest that the Department should bring out annual reports giving a survey of the important activities of the Department on the same lines as is being done by the Department of Archaeology.

60. The Committee are not aware whether the results of the survey and researches made by the staff of this Department which are published in the Bulletins, Memoirs etc. are utilised by the Government Officers who are called upon to serve in the tribal areas. They suggest that all Government officers who are required to serve in the tribal areas should be required to read relevant literature published by this Department and familiarise themselves adequately with the habits, customs, social attitudes, psychological reactions etc. of the tribes.

61. The Committee were informed that it was a practice with the Ministry of Home Affairs to encourage the study of tribal languages by Government officers serving in tribal areas. They were, however, told that in the past officers who knew tribal languages used to be given language allowance during the period of their service in the tribal areas. They were also told that that practice was no longer in vogue. The Committee suggest that with a view to encouraging officers who might be called upon to serve in tribal areas to learn tribal languages, the advisability of reviving the language allowance may be considered.

62. The Committee suggest the following for a well integrated programme in dealing with tribal population:

- (a) *A regular training of Anthropology for Administrators in tribal areas.*

- (b) *Officers who know tribal languages and who have done a course in Anthropology to be preferred for posting in tribal areas.*
- (c) *Anthropology to be one of the subjects in the I.A.S. Training Course.*

63. The Committee understand that at present there is no co-ordination maintained between this Department and the Ministry of Information and Broadcasting in regard to the exhibition of films made by the former about the life of the various Indian Tribes. The Committee consider that some of these films could perhaps be utilised with advantage by the Ministry of Information and Broadcasting for educational purposes. *They, therefore, suggest a closer collaboration between this Department and the Ministry of Information and Broadcasting in this regard.*

64. The following Universities have Departments of Anthropology:—

- (i) Calcutta
- (ii) Delhi
- (iii) Gauhati
- (iv) Bihar (Social Anthropology only)
- (v) Lucknow
- (vi) Patna (Social Anthropology including Economics)
- (vii) Madras (Diploma only)
- (viii) Saugar.

The Committee recommend that the existing University Departments of Anthropology may be strengthened and other Universities persuaded to create departments of Anthropology so as to stimulate interest in this subject.

IV. MUSEUMS

A list of Museums in India under the following categories is placed at Appendix IX:

- (a) Central Government Museums
- (b) State Government Museums
- (c) Universities Museums
- (d) Other Museums.

Of the Central Government Museums, the National Museum and the Central Asian Antiquities Museum are briefly dealt with below:

A. The National Museum of India

(a) *Historical Background*

66. The initiative for the establishment of a National Museum in India was taken by the Asiatic Society, Calcutta. The Government accepted the suggestion and a scheme for a Central Museum of Art, Archaeology and Anthropology was drawn up in 1945 by the Director General of Archaeology in India. The scheme was approved by the Central Advisory Board of Archaeology and also by the Indian Legislature Standing Advisory Committee on Education. The Government of India appointed a Committee with Sir Maurice Gwyer as its Chairman, to examine the whole question. The Committee's detailed report, published in 1946, was finally accepted by the Ministry of Education in 1947. A site for the proposed National Museum was selected near the crossing of Jan Path at the Central Vista, New Delhi.

67. The exhibition of Indian Art and Archaeology held in London in 1947-48 was the prelude, though indirectly, to the formation of the nucleus of the National Museum. The entire collection displayed at the Exhibition was brought to Delhi and an Indian Art Exhibition was organised in the State Rooms of the Rashtrapati Bhavan. Several masterpieces of sculptures in bronze and stone, and paintings of different schools were exhibited. The Government of India appealed to the owners of the art objects for an extended loan. Favourable response having been received, the Central Cabinet decided to make use of the State Rooms of the Rashtrapati Bhavan for the Museum. This nucleus of the National Museum has accordingly been established in the capital with a view to collecting, conserving and displaying the unrivalled heritage of the country in art and culture. This Museum, when fully developed, will serve as a great source of education to the visitors.

68. The new building for the National Museum is estimated to cost Rs. 77.63 lakhs. This amount has been included in the Second Five Year Plan. The construction of the building has been divided into four phases. The first phase is expected to be ready by 1958.

(b) *Organisation*

69. An organisational chart of the National Museum in accordance with the Gwyer Committee Report is placed at Appendix X. The organisational set up of the National Museum consists of the following Departments:—

1. Directorate;
2. Department of Art;
3. Pre-historic Archaeology Department;
4. Historic Archaeology Department (Buddhist, Jaina, Brahminical and Muslim);
5. Numismatics and Epigraphy Department; and
6. Anthropology (Cultural and Physical Department).

In addition to these departments, there will be a Circulation Department, a Library and a Chemical Laboratory. The Directorate will consist of a Director and an Assistant Director, whose duties will include directive, publicity and liaison, a Secretary, highly qualified Librarian and a Superintendent of Publications. There will also be at least one Guide Lecturer for each of the five main Departments. Each of the above Departments will be in charge of a Keeper/Deputy Keeper. *The Committee are of the view that the proposed staff is on the high side, and suggest that the position may be re-examined in consultation with the O & M Division.*

70. The National Museum at present functions as a subordinate office of the Ministry of Education and Scientific Research. The Committee were informed that the decision to make the National Museum a subordinate office of the Ministry instead of setting up as an autonomous body as recommended by the Gwyer Committee was purely provisional because the Museum was yet in a formative stage. They were further informed that when the Museum developed into a full-fledged institution, the question to make it an autonomous body would be considered. *The Committee agree with the recommendation made by the Gwyer Committee that the National Museum should, in accordance with the successful precedent of the British Museum, be set up as an autonomous body as soon as possible.*

(c) *Scope and Functions*

71. The scope and functions of the National Museum cover Art, Archaeology and Anthropology. The present collections are partly from the Museums under the control of the Department of Archaeology and partly from purchases. The collections are being enriched further by new acquisitions through an expert Art Purchase Committee. At present the main sections in the Museum are devoted to the following:—

- (i) Pre-historic and Indus Valley Civilization;

- (ii) Stone sculptures from the Mauryan Era to the late Medieval period;
- (iii) Bronzes both North Indian and South Indian;
- (iv) Miniature paintings representing the various schools in the country; and
- (v) Minor antiquities—arms, and weapons, objects of jade, painted book covers, illuminated manuscripts, etc.

This collection, as a whole, presents a comprehensive picture of the art and culture of India through the ages. The objects in the Museum belong to periods ranging from ancient times to the 19th century.

(d) *Personnel*

72. The Committee understand that the post of Assistant Director has been lying vacant since August, 1954. *The Committee were surprised to learn that in spite of the efforts of the Ministry through the U.P.S.C. and directly it has not been possible to recruit the Assistant Director for the Museum. The Committee are of the opinion that for the proper development of the Museum, it is necessary that the post of the Assistant Director should be filled as early as possible.*

The Committee understand that eventually it is proposed to appoint a Director in charge of the Museum; and that this post has not yet been formally created because of the difficulty of getting an eminent Museologist for this purpose. *The Committee suggest that a suitable person may be selected for this purpose and then given intensive training in India or abroad.*

73. The Committee understand that no definite scheme for training of staff has been formulated but the staff can avail of the scheme for the training of keepers or curators in service) and In-service Chemical Assistants for preservation of art objects for all the Museums in India, which have been accepted by the Government in pursuance of the recommendations of the Central Advisory Board of Museums. The training Centre for In-service Keepers or Curators is proposed to be established at the Prince of Wales Museum, Bombay while arrangements for imparting training to Chemical Assistants are proposed to be made at the Central Asian Antiquities Museum, New Delhi and the Chemical Department of the Department of Archaeology at Dehradun. The Committee learnt with regret that the courses of training referred to above which were to have started with effect from October, 1957 did not start as scheduled.

74. In view of the shortage of properly trained personnel for the National Museum, and other Museums in the country, the Committee consider that it is essential that a high priority should be given to the training of those who are already working in the Museums and the training of additional personnel. *The Committee*

suggest that a scheme should be drawn up to impart training to the entire staff of the National Museum. The scheme should be extended early to other Museums in the country also.

(e) *Activities*

(i) *Collections*

75. The total number of exhibits in the National Museum is 35,284. The total number of exhibits on display is 1738, while the number kept in reserve is 33,546. In other words, only 5 per cent of art objects with the National Museum are on display. It was explained that a larger number of objects could not be displayed due to lack of space. It was stated that a large space would become available during 1958 for the display of art objects. It was also stated that at one time perhaps 50 per cent of the exhibits could be displayed and 50 per cent stored.

The Committee suggest that rather than keeping a large percentage of exhibits in godowns, some systematic arrangement may be devised under which some of the exhibits can be lent to the State Museums so that people might benefit from them. The Committee also suggest that the National Museum should use its good offices to have the replicas made of the selected exhibits of each Museum so that they can be distributed to all the important Museums in the country.

76. The Committee understand that all art objects have been entered in the General Accession Register with the exception of 400 beads, 400 miscellaneous objects and nearly 5000 arms, which were received by the Museum in 1956 and 1957. *The Committee regret to note that these objects were not entered in the Accession Register for more than a year. The Committee are also surprised to learn that during the last 1½ years no inventory was maintained in which an article was entered as soon as it was received. It is a very sad state of affairs. The Committee suggest that this may be remedied at once.*

77. The Committee were informed that the present practice was that as soon as an object was received it was entered into the General Acquisition Register within three days. It was later entered into special acquisition register where the object was described in detail. The whole process took about a month. The Committee were also informed that a physical verification of objects was going on and a special officer had been entrusted with this work. They were told that some losses had been discovered and action was being taken to find out whether they were actual losses or the objects had been mixed up somewhere. *This cannot be considered to be satisfactory.*

78. There is at present no catalogue of the collections in the Museum. *The Committee suggest that a catalogue of the collections should be maintained.*

(ii) Research

79. There are at present no facilities available in the Museum for research scholars to conduct research. *The Committee consider that it is desirable that proper facilities for research should be made available to research scholars as early as possible.*

(iii) Educational Services

80. The Committee were informed that no lectures had been arranged by the Museum since 1951-52 for the benefit of students and scholars for want of adequate staff and space. They were also informed that there was no coordination maintained between the National Museum and Educational Institutions except that special tours were conducted for the benefit of students of recognised educational institutions.

81. *The Committee suggest that lectures both popular and scientific should be arranged by the Museum, for the benefit of students and research scholars with prior arrangement with Universities and other Institutions interested in the subject. The Committee would also like to emphasise the desirability of maintaining close coordination between the Museum and educational institutions as the Museum is one of the most important agencies of education.*

(iv) Co-ordination with foreign Institutes

82. The Committee understand that there is at present no co-ordination maintained between the National Museum and its counterparts in the foreign countries. *The Committee suggest that it would be desirable to maintain co-ordination with foreign museums in order to benefit from the latest museum techniques and processes.*

(f) Budget and Finance

83. A statement showing details of the budget estimates and actual expenditure of the National Museum during the last three years is attached at Appendix XI.

84. A provision of Rs. 4,00,000 has been made for 1957-58. It was explained that the wide variation between the budget estimates and the actual expenditure was due to the fact that the National Museum was still in the formative state and many vacancies had remained unfilled because the technical personnel were not available. It was also stated that the development schemes as contemplated could not be fulfilled during each year, resulting in shortfalls. *The Committee consider this as rather unfortunate and stress the necessity of framing budget estimates in a more realistic manner.*

B. Central Asian Antiquities Museum**(a) Introduction**

85. The Central Asian Antiquities Museum was formed in 1929. The Museum is constituted of the collections brought by Sir Aurel

Stein from his expeditions to Chinese Turkestan in 1900-01, 1906-08 and 1913-16 which reveal cultural ties that had existed between the West and the Far East on the one hand and India on the other. This Museum is under the administrative control of the Department of Archaeology.

(b) *Scope and Functions*

86. The Museum has a varied collection consisting of Terracottas, Stuccos, carved wooden pieces, documents and paintings on walls, silk, wooden board and papers, besides other minor antiquities covering a period from first to tenth centuries A.D.

(c) *Collections*

87. There are 9796 art objects in the Museum. Of these 2296 have been exhibited while 7500 are kept in reserve. All the exhibits are catalogued.

(d) *Library*

88. There are about 2000 books in the library. The Committee understand that no catalogue of the books available in the library has been printed. *The Committee suggest that a catalogue may be printed and published for the benefit of scholars.*

89. The Committee learn that arrangements for guiding research students are lacking. *The Committee suggest that suitable arrangements in this regard should be made.*

(e) *Educational Services*

90. The Committee learn that no lectures or classes are held for the benefit of the research students. *The Committee suggest that lectures should be arranged periodically in collaboration with the National Museum and the Delhi University.*

(f) *Research*

91. The Committee understand that so far there has been no co-ordination maintained between this Museum and other Museums and Universities in research in museology. *The Committee suggest that necessary co-ordination in this regard may be maintained.*

(g) *Laboratory*

92. The Museum has a good laboratory where chemical treatment for the preservation of exhibits is given. The Committee were informed that training to the staff of other Museums in techniques of preservation was imparted by this Museum. The Committee, however, learnt that only 5 employees of other Museums received training during the last five years. This is highly unsatisfactory. *The Committee are of the opinion that training facilities should be expanded and better utilised.*

93. On the question of co-ordination among the Central Asian Antiquities Museum, the National Museum, National Archives of India and other Museums in regard to the work of preservation and of the advisability of having one Central Preservation Department doing all preservation work including research, it was stated before the Committee that in some countries this work was centralised at the stage of research. It was added that when research was conducted in the methods of preservation, it would be best to have one institution for the whole country, but if it was preservation under a particular institution, it must necessarily be a distinct part of that institution. *The Committee suggest that the feasibility of having a centralised agency for doing preservation work of the various government departments should be examined. In the meantime, effective steps should be taken to have greater co-ordination between the various institutions mentioned above, in regard to the work of preservation.*

(h) *Future of the Central Asian Antiquities Museum*

94. *The Committee suggest that as soon as the first phase of the development of the National Museum is completed, the Central Asian Antiquities Museum should become part of the National Museum.*

C. Indian Museum, Calcutta

95. The Indian Museum, Calcutta, was established in 1866 under the Indian Museum Act of 1866, which has been amended from time to time. In 1865, it was arranged that the Society should make over to the Board of Trustees for the proposed Museum the Zoological, Geological and Archaeological collections and that Government should provide suitable accommodation for the Society in the Museum building. Legislative sanction to this was accorded by the Indian Museum Act of 1866. In 1887, the Economic and Art Section, which had formed a separate institution under the direct control of the Government of Bengal was placed under the Trustees of the Indian Museum.

96. At present, the following Sections constitute the Indian Museum:—

- (i) Archaeological Section;
- (ii) Zoological Section;
- (iii) Anthropological Section;
- (iv) Geological Section;
- (v) Art Section; and
- (vi) Industrial Section (Economic Botany).

Out of these, only the Art Section is under the direct control of the Trustees, but the Keeper of the Section is the Principal of the Government College of Arts and Crafts, which is under the West

Bengal Government. The other Sections are under the administrative control of the respective surveys. The Archaeological Section is under the Archaeological Survey, the Zoological Section is under the Zoological Survey of India, the Anthropological Section is under the Department of Anthropology, and the Industrial Section is under the Botanical Survey of India. Thus the collections in the Museum are being organised by five different departments of the Government of India, while legally they vest in the Board of Trustees for the purposes of the Museum. The trustees are only concerned with the galleries of the Museum and the Exhibits displayed therein. In addition to this, the West Bengal Government runs its Government College of Arts and Crafts and thus controls the Art Section through its Principal who is *ex-officio* Keeper of the Section. An organisational chart of the Indian Museum is given as Appendix XII.

Finances

97. The Sub-Committees of the Estimates Committee which visited the Indian Museum were told that the major sources of revenues of the Indian Museum in so far as they concern the Trustees were as follows:—

- (i) Grant from the Government of India for the pay of establishment of the Trustees Office and Art Section, for office contingencies and for Municipal taxes.
- (ii) Grant from the Government of West Bengal (a) for lectures and (b) for pay of bearer attached to the Nahar Collection which has been placed in the Indian Museum through special arrangement.
- (iii) Sale of publications by the Trustees.
- (iv) Angling fee in the Museum Tank;
- (v) Miscellaneous receipts, such as rent of paintings, sale proceeds of petty articles etc.

Admission fee is charged on Fridays from the visitors to the Museum. Sale proceeds and gate collections are credited to the Government of India.

98. The grants-in-aid given to the Indian Museum during 1955-56, 1956-57 and 1957-58 are given below:—

(in lakhs of rupees)

1955-56	1956-57		1957-58
Actuals	Budget Estimates	Revised Estimates	Budget Estimates
1.31	1.30	1.32	1.39

General

99. The Sub-Committees when they visited the Indian Museum were informed that over 15 lakhs of people now visit the Museum in a year and the number is still increasing. This includes a fair number of foreign visitors. The available space is wholly inadequate to accommodate its vast collection as required by modern standards. It was brought to the notice of the Sub-Committees that the textile collection of the Museum was good but it was not exhibited for want of space and no purchases worth the name were made after 1936 for want of funds. The Committee suggest that suitable steps may be taken to exhibit the rich textile collections. The Committee also suggest that the question of transferring the Museum to the State Government may be examined.

100. The Committee understand that a Plan submitted by the Trustees is awaiting decision of the Government of India. The main needs of the Indian Museum *viz.*, (a) Extra accommodation and building projects, (b) an unified control of the Indian Museum with all its sections, laboratories and libraries and of the necessary staff; (c) provision of modern techniques as employed in the Museums in progressive countries for preservation, publicity and educational programme and (d) provision for gallery expansion *viz.* Science, Museum, Children Museum, a big public hall, are dealt with in the Plan in question. *The Committee suggest that the decision of the Government in the matter may be expedited.*

101. *Pending final approval and implementation of the Plan of Development suggested by the Trustees, the Committee suggest that the following important and immediate problems of internal management should be attended to without delay:*

- (a) *more accommodation;*
- (b) *more amenities for visitors;*
- (c) *better arrangements of the exhibits, and for explanations to visitors;*
- (d) *repairs of the exhibits, renovations and addition of new items; and*
- (e) *publication of catalogues and other materials for the better service of the public.*

D. General

Development of State Museums

102. There is a scheme of development of principal State Museums and University Museums of all-India character. The State Governments were requested in February, 1957 to submit detailed proposals for the development of Museums in their respective jurisdictions, for the consideration of the Government and also to make suitable provisions in the Second Five Year Plan on a 50-50 basis. The Committee understand that no definite proposals have so far been

received and that consequently, no substantial progress has been made in this direction. *The Committee suggest that the question of revising the scheme, so that the Centre might give 50%, the State Governments 25%, and other local organisations like the Universities the local bodies, etc. 25% may be examined, so that the scheme might make a headway. The Committee suggest that the scheme should include grants towards the expenses of trained staff in local museums. The Committee feel that the State Governments also should consider it their duty to encourage the development of museums by at least coming forward with their share of 25% if not 50 per cent as was contemplated in the original schemes. The Committee further feel that the museums should not remain at the stage in which they were in the 19th century and that it is desirable that they make some progress with a concrete programme.*

V. NATIONAL GALLERY OF MODERN ART

A. Historical Background

103. The need for a National Gallery of Modern Art had been engaging the attention of the Government of India ever since the country became Independent. The Conference of Arts held in 1949 at Calcutta gave further impetus to this idea by recommending the establishment of a National Gallery. As a result, the National Gallery of Modern Art was inaugurated on the 29th March, 1954 at Jai-pur House in New Delhi.

B. Organisation and Functions

104. The National Gallery of Modern Art is a sub-ordinate office under the direct administrative control of the Ministry of Education and Scientific Research. Its functions and scope are to exhibit Indian pictorial sculptural art (including illuminated manuscripts) from the year 1857 including examples of the higher craftsmanship of artistic value. *The Committee suggest that the National Gallery of Modern Art should be transferred to an autonomous or semi-autonomous body like the Lalit Kala Akadami or the Fine Arts Society.*

C. Collections

105. The work of collecting modern paintings for the Gallery was first started when the Government of India acquired 30 paintings of Amrita Sher Gill in 1948-49. Paintings of other Indian Artists were acquired subsequently and the Gallery now possesses works of nearly 30 artists, including Rabindranath Tagore, Abanindra Nath Tagore, Nand Lal Bose, Jaimini Roy, Sailoz Mookerjee and A. R. Chughtai.

106. The total number of objects with the Gallery is 1774. Out of this only 374 have been exhibited, 133 are in reserve, and 1266 in store. The reserve collection consists mostly of oil paintings and is shown with the permission of the Curator to scholars of Art. The paintings in store are exhibited by turns. *The Committee suggest that some sort of exchange of objects or exhibitions with other Galleries should be arranged so that people in other places would also benefit from them.*

D. Educational Services

107. *The Committee are glad to learn that monthly lectures are arranged by the Gallery in New Delhi. The Committee suggest that similar lectures should be arranged also in other parts of the country.*

E. Personnel

108. The Committee learn that there is a shortage of technical personnel for the National Gallery and that some of the personnel might have to be trained abroad, especially the Restorer, because the technique of restoration does not exist in India. *The Committee suggest that necessary steps should be taken as early as possible to overcome the shortage of technical personnel. In the meantime, frequent advice and guidance should be obtained from the preservation experts of the Museums and of the Archaeological Department, as well as of the National Archives.*

F. Air-conditioning of Accommodation occupied by the National Gallery

109. The Committee understand that a small portion of Jaipur House which houses the National Gallery of Modern Art has been air-conditioned for the proper preservation of oil paintings, and also that there is a proposal to air-condition the entire building at an estimated cost of Rs. 7,50,000. A provision of Rs. 50,000 on this account has been made in the budget estimates for the year 1957-58. The Committee understand that Jaipur House has not yet been purchased by the Government of India. *The Committee suggest that before the proposal to air-condition the building is proceeded with, steps might be taken by the Government to purchase the building, if necessary.*

VI. NATIONAL LIBRARY, CALCUTTA

A. History

110. The first foundation of this Library was laid on the 8th March 1936, when Dwarka Nath Tagore and Pyari Chand Mitra founded the Calcutta Public Library. The Librarian explained to the Sub-Committees which visited the National Library that the most significant development in the history of the Library took place soon after the attainment of Independence when it was converted into the National Library and, on the recommendation of the then Governor General India, Belvedere Mansion became the permanent habitation of the Library.

B. Management

111. The Library is a sub-ordinate Department of the Ministry of Education and Scientific Research. The control and management of this Library is vested in a Council consisting of twelve members including the Educational Adviser to the Government of India as Chairman and the Librarian as Secretary. An organisation chart of the Library is given at Appendix XIII. The Librarian has been vested with all the financial powers of the Head of Department.

C. Functions

112. It is a Library of reference, working place for students and repository of materials for the future historians of India, in which as far as possible, every work written in and about India as well as by Indians abroad can be seen and read. Besides being a lending Library for individual as well as institutional loans for the entire country, it is also an International loans and books exchange centre.

113. General and special reference enquiries are attended to. Bibliographies and microfilm copies of the printed books and manuscripts are supplied on request. Technical advice on matters connected with the administration and organisation of libraries is also given. Facilities are also offered to nominees of Government Departments and other approved institutions for practical training. It also offers facilities for running the Librarianship Training Courses conducted by the Bengal Library Association and the Calcutta University. *The Committee recommend that the feasibility of all Librarians of Public and University Libraries being trained in this unique Institution may be examined.*

114. The Library organises exhibitions of its rare material on special occasions as well as participates in Book Exhibitions organised under the auspices of approved bodies.

D. Reorganisation

115. The Sub-Committees were informed that for the sake of smooth administration and rendering better service to the public, the whole set up of the Library was reorganised in 1950 into the following divisions and sections:—

- (i) Acquisition Division.
- (ii) Cataloguing Division No. I.
- (iii) Cataloguing Division No. II.
- (iv)* Bibliography and Reference Division.
- (v) Reading Rooms Division.
- (vi) Lending Section.
- (vii) Stacking and Book-binding Division.
- (viii) Administration Division.

Donors like the Asutosh Mukhopadhyaya family, the Ramdas Sen family and such others gave to the Library rare private collections. The annual book purchase grant for the Library has been increasing from a mere Rs. 20,000/- in 1950-51 to about a lakh of rupees during the year 1957-58. By the provisions of the Delivery of Books (Public Libraries) Act, 1954, every publication in the country has to accrue to this Library through the publisher within a month of its publication.

116. The cataloguing of the Library falls into two divisions one for the European Languages and the other for the Asian Languages. The Members were told that the Library has the largest collection of Indian official publications from the earliest time to the present day, consisting of nearly 75,000 units. The cataloguing of the Indian official publications is a highly technical job and the Committee are glad to learn that this has now been undertaken by the Library. All the new acquisitions are now being classified according to the Dewey Decimal System of classification, with special schedules worked out for Indian subjects. The Reference Collection has been classified on the Dewey Decimal Scheme.

117. The primary responsibilities of the Bibliography Division have been the compilation of a Bibliography of Indology, covering all aspects of the cultural achievements of this country. A very significant contribution of this Division towards international bibliography has been the compilation of entries for the *Index Translationum* published by the UNESCO every year.

118. The main activity of the Reading Room of the National Library manifests itself in the actual servicing of books to the readers. When the Library shifted to Belvedere, it was thought that being an out of the way place, not many would be able to enjoy the facilities of the Reading Room. The Members of the Sub-Committees were informed that on an average about 500 readers per day come to the Library and on Saturdays, Sundays and holidays, the number some-

times goes upto 750 and difficulty is experienced in finding accommodation for the readers. The Reading Room has convenient sitting accommodation for 300 persons at a time. The Lending Section deals not only with local borrowers but also with borrowers all over India and outside. It is also the centre of the international loan of books and during recent years the Library has been able to procure for their scholars book service and microfilm service from abroad. The liaison that the Section maintains with the National Central Library in London and the Library of Congress in Washington, was reported to be most fruitful. Books have been sent from here to China, Thailand and Pakistan on requisition. The Library is open all the days in the year except for three days (the Republic Day, the Independence Day and Mahatma Gandhi's Birthday). It is open from 9 A.M. till 8 P.M. on all days except on Sundays and holidays when it is open from 10 A.M. to 5 P.M. *The Committee suggest that similar facilities should be made available in other State Libraries also.*

119. To solve the problem of limited accommodation, the rolling stock of rubber wheels has been recently evolved. Today, there are 800 rolling stacks, each with a capacity for 350 volumes, housing a big part of the Library's Books. This works out to 12 miles of shelving, all in steel, accommodating nearly 8.65,000 of volumes that the Library possesses.

120. The Sub-Committees were informed that it is proposed to have the actual binding establishment under the Library's care, and that the construction of an Annexe under the Second Five Year Plan for which a sum of Rs. 7,40,000 has been set apart, has been accepted by Government and that Government Architect has been planning for the new Annexe.

E. General Activities

121. A brief resume of the important activities of the National Library is enclosed herewith as Appendix XIV.

F. Second Five Year Plan

122. The Governing Council of the Library have suggested the inclusion of the projects as detailed below in the Second Five Year Plan:—

	Rs.
(a) Construction of an Annexe to the main building of the Library at Belvedere	7,40,000
(b) Setting up of the Library's Home Bindery	80,000
(c) Reorganisation of entire Card Catalogues	60,000
(d) Compilation of Bibliography of Indology	20,000
(e) Children's Library	1,20,000
TOTAL	10,00,000

123. The Committee were given to understand that a sum of Rs. one lakh has been sanctioned for the year 1957-58 for starting the work of the projects mentioned against (b), (c) and (d) and accordingly the work in connection therewith has been taken in hand.

124. *The Committee were well impressed with the way the Library was being run. They would like all Libraries in India to draw from the rich experience of the Library and recommend that Government should expand the facilities in the National Library for training, reference, lending etc. to serve this end. The Committee are of the opinion that it would be useful for the Librarians in charge of other big libraries in the country to be deputed to spend a few weeks in National Library, so that they may get familiarised with the modern techniques of library science.*

NEW DELHI;
The 7th April, 1958.

BALVANTRAY G. MEHTA,
Chairman,
Estimates Committee.

APPENDIX I

(Vide para 2)

Statement showing details of the various Branches in each Division of the National Archives of India and the work done therein

DIRECTOR OF ARCHIVES

Deputy Director of Archives (vacant)

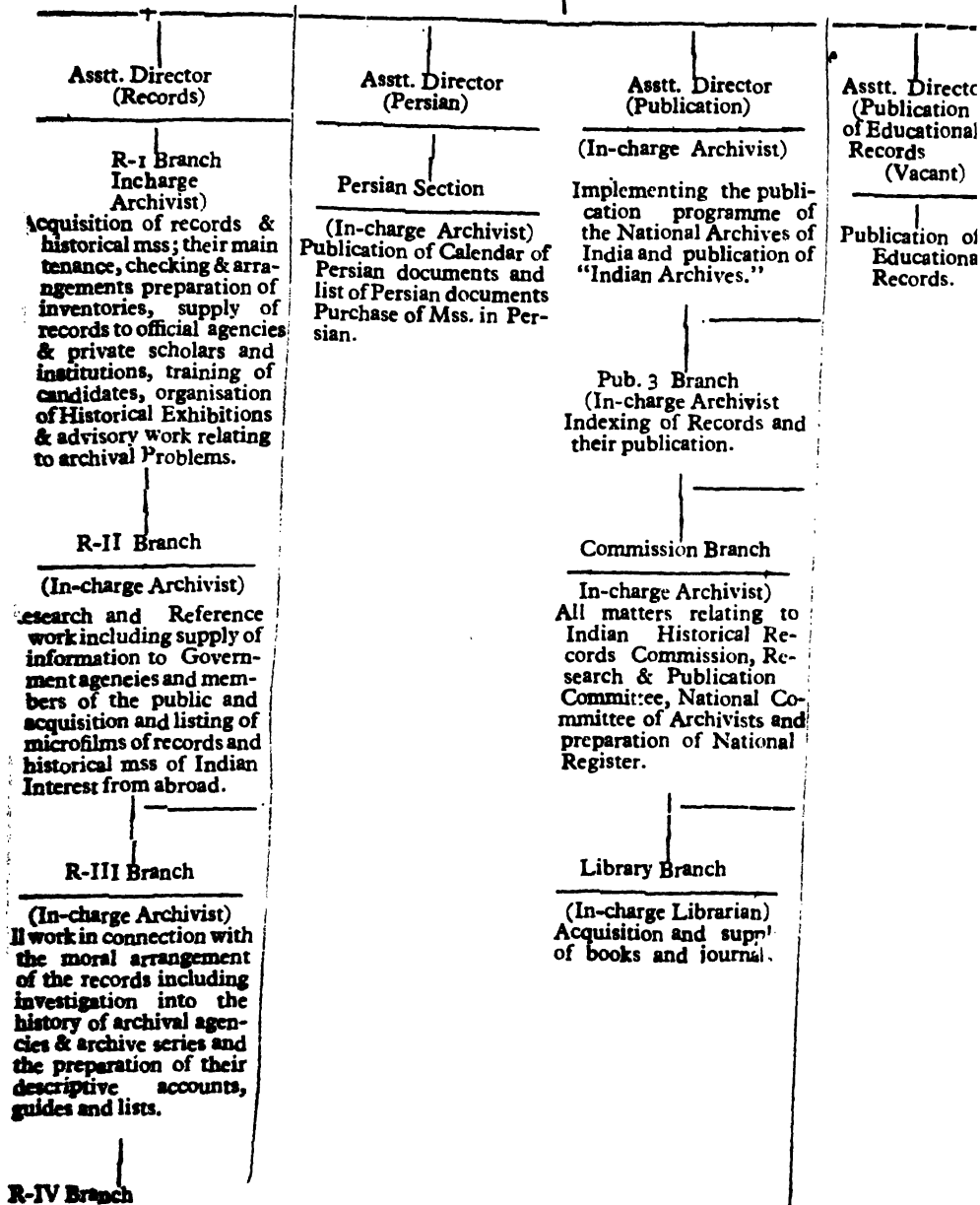

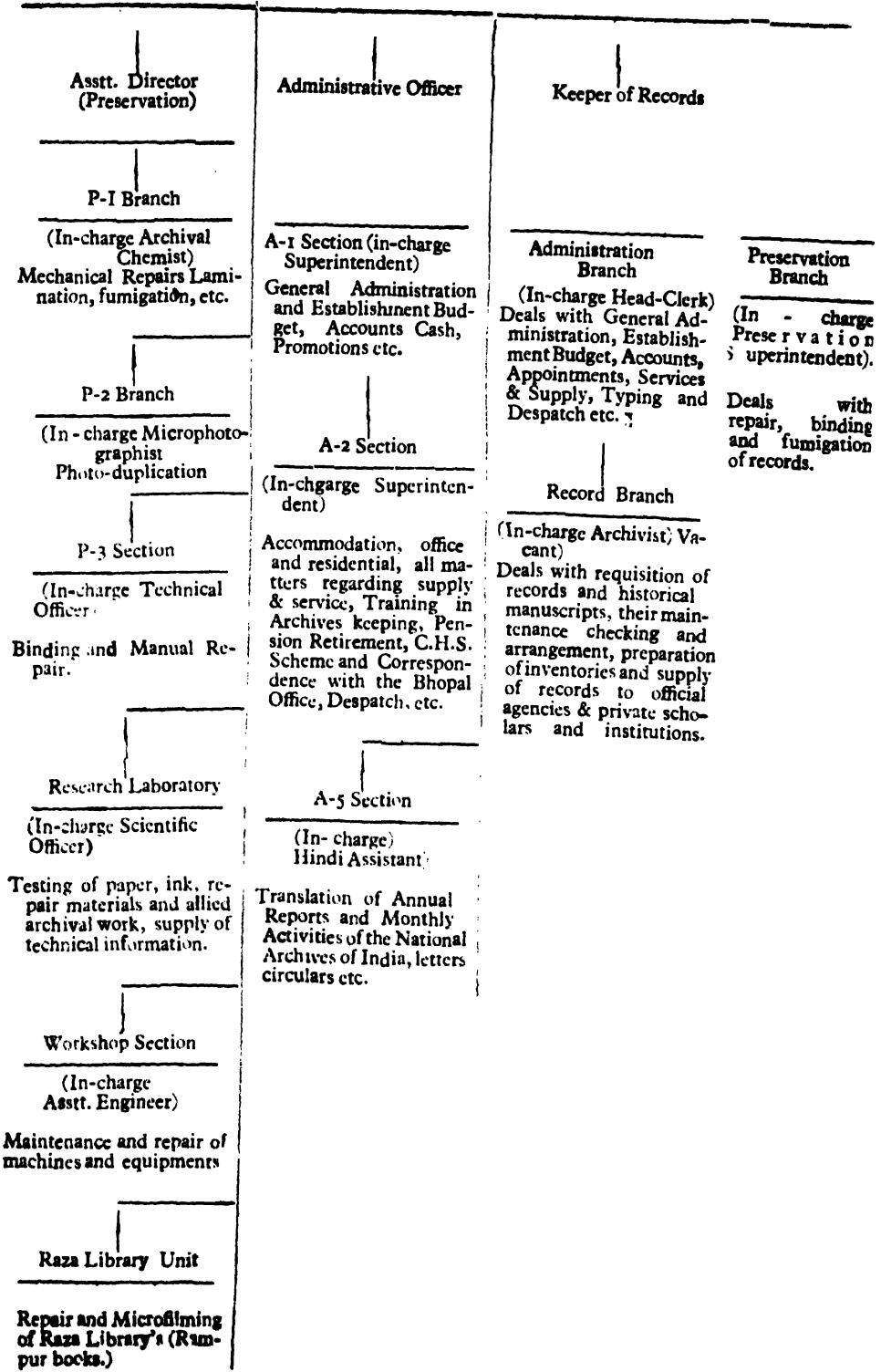

Asstt. Director (Preservation)

P-I Branch

(In-charge Archival Chemist)
Mechanical Repairs Lamination, fumigation, etc.

P-2 Branch

(In-charge Microphotographer)
Photo-duplication

P-3 Section

(In-charge Technical Officer)
Binding and Manual Repair.

Research Laboratory

(In-charge Scientific Officer)
Testing of paper, ink, repair materials and allied archival work, supply of technical information.

Workshop Section

(In-charge Asstt. Engineer)
Maintenance and repair of machines and equipments

Raza Library Unit

Repair and Microfilming of Raza Library's (Rampur books.)

Administrative Officer

A-1 Section (in-charge Superintendent)
General Administration and Establishment Budget, Accounts Cash, Promotions etc.

A-2 Section

(In-charge Superintendent)
Accommodation, office and residential, all matters regarding supply & service, Training in Archives keeping, Pension Retirement, C.H.S. Scheme and Correspondence with the Bhopal Office, Despatch, etc.

A-5 Section

(In-charge) Hindi Assistant
Translation of Annual Reports and Monthly Activities of the National Archives of India, letters circulars etc.

Keeper of Records

Administration Branch
(In-charge Head-Clerk)
Deals with General Administration, Establishment Budget, Accounts, Appointments, Services & Supply, Typing and Despatch etc.

Record Branch

(In-charge Archivist) Vacant
Deals with requisition of records and historical manuscripts, their maintenance checking and arrangement, preparation of inventories and supply of records to official agencies & private scholars and institutions.

Preservation Branch

(In-charge Preservation Superintendent)
Deals with repair, binding and fumigation of records.

APPENDIX II

(Vide para 5)

Statement showing the details of activities of the N.A.I. under Publications

On the recommendation of the Indian Historical Records Commission at its Mysore Session, 1942 the following publication programme was undertaken by the Department with the approval of the Government of India :—

Scheme I—For William-Indian House Correspondence

This scheme envisages printing in extension of the General letters to and from the Court of Directors from 1748 to 1800 in 21 volumes. The volumes are edited by the scholars appointed by the Government of India in this behalf. Each of the volumes contains the text of the correspondence together with a comprehensive introduction, notes, bibliography, and an exhaustive index.

Scheme II—Selections from English Records.

The publications planned under the scheme are (i) Major Browne's Correspondence with Warren Hastings (ii) Sir John Shore's Minutes and (iii) Indian Travels of Thevenot and Careri. These volumes are to be edited exclusively by the Director of Archives with the help of his staff.

Scheme III

This scheme envisages the editing and publication in collaboration with outside agencies of (a) Records on oriental languages and (b) selections from English Records.

In addition to the above the following publications are also being brought out by the Department :—

Calendar of Persian Correspondence

This series which started in 1911 gives a summary in English of the Correspondence in Persian between the Governor General and other agents of the English East India Company on the one hand and other oriental rulers and dignitaries on the other.

Indices to Records

The National Archives of India has undertaken to publish indices to the pre-1859 records in its custody.

A copy of the catalogue of publications of the National Archives of India is placed at Annexure.

ANNEXURE TO APPENDIX II

Catalogue of Publications of the National Archives of India.

I. Clive (Rt. Hon. Robert, 1st Baron). A printed collection containing copies of papers from Bengal, Madras and the India Office, relating to Clive

(1744-67), with others illustrating the rise of the British power in India, (1671-1785), in 3 vols. Compiled by G. W. Forrest, Calcutta, 1891-3.

2. Press-list of the above papers, for the period 1746-1785. Calcutta, 1902.

3. Press-list of the copies of Persian Correspondence (Receipts) in bound volumes, 1769-1801. Calcutta, 1904.

4. Lists of Original Treaties, Engagements, etc. transferred from the Foreign Department to the Imperial Record Office. 3 vols. Calcutta, 1901-8.

5. Lists of the Records of the Government of India preserved in the Imperial Record Office. 10 vols. Calcutta 1904-10.

6. Selections from the letters, despatches and other State papers preserved in the Military Department of the Government of India, 1857-58. 4 vols. Edited by G. W. Forrest, Calcutta, 1893-1912.

7. Index to the press-list of ancient documents belonging to the Public Department for the years 1749-59 (1760-69). Vols. I, II. Calcutta, 1910-16.

8. Press-list of records belonging to the Foreign Departments of the Government of India. Calcutta, 1917-18.

Series I. Select Committee, 1756-74.

Series III. Secret Department, Vol. I, 1763-75.

Series IV. Secret Department of Inspection, 1770-87.

9. Kabul papers. 1839-59. Jagir statements, 1847-57. Calcutta, 1919.

10. Press-list of Mutiny papers, 1857, with Index. Calcutta, 1921.

11. Press-list of ancient documents preserved in the Imperial Record Room of the Government of India, Public Department, 1748-1800, including copies of documents obtained from the India Office. 20 vols. Calcutta, 1898-1922.

12. An abstract of the early records of the Foreign Department, Part I. 1756-62. By S. C. Hill, Calcutta, 1901.

13. A Hand-book to the Records of the Government of India in the Imperial Record Department, 1784-1859. Calcutta, 1925.

14. List of the Heads of Administrations in India and of the India Office in England corrected to April, 1938. New Delhi, 1939.

15. Index to the Land Revenue Records, 1830-59 vols, I, II, (1940-42).

16. Calendar of Persian Correspondence :

Vol. I. 1759-67 Editor : E. Denison Ross Published in 1911

Vol. II 1767-69, Editor : A. F. Scholfield „ „ 1914

Vol. III 1770-72, Editor : A. F. Scholfield „ „ 1919

Vol. IV 1772-75, Editor. A. F. M. Abdul Ali „ „ 1925

Vol. V 1776-80, Editor : A. F. M. Abdul Ali „ „ 1930

Vol. VI 1781-85, Editor : A. F. M. Abdul Ali „ „ 1938

Vol. VII 1785-87, Editor : S. N. Sen „ „ 1940

Vol. VIII 1788-89, Editor : B. A. Saletore „ „ 1953

Vol. IX 1790-91, Editor : S. N. Sen „ „ 1949

17. For William—India House Correspondence (Scheme I of the Publication Programme in 21 volumes)

Vol. V. 1767-69, Public Department

Editor : Narendra Krishna Sinha. Published in 1949.

Vol. XVII, 1792-95, Foreign Political and Secret Department.

Editor : Y. J. Taraporewala. Published in 1956.

Vol. II 1757-59 Public Department

Editor : H. N. Sinha. Published in 1957.

18. Selections from English Records (Scheme II of the Publication Programme).

Indian Travels of Thevenot and Careri,

Editor S. N. Sen, Published in 1949.

19. Records in Oriental Languages [Scheme III (a) of the Publication Programme].

Prachin Bangala Patra Sankalan

1779-1820 Editor : S. N. Sen Published in 1942 by the Calcutta University.

Sanskrit Documents,

1778-1855, Editors : S. N. Sen and Umesh Misra Published in 1952 by the Ganganath Jha Research Institute.

20. Selections from English Records [Scheme III (b) of the Publication Programme].

Selections from orme Manuscripts,

Editor : C. S. Srinivasachariar Published in 1952 by the Annamalai University.

Punjab Akhbars,

1838-41, Editor : Ganda Singh, Published in 1952 by the Sikh History Society, Patiala.

List of Publications of the National Archives of India in the Press

(1) Fort William—India House Correspondence (Scheme I of the Publication Programme).

Vol. I, 1748-56 : Public Department. Editor : Dr. Kali Kinkar Datta, M.A., Ph.D.

Vol. IV, 1770-72 : Public Department. Editor : Dr. Bisheshwar Prasad, M.A., D.Litt.

Vol. IX, 1782-85 : Public Department. Editor : Dr. B.A. Suletoro M.A., Ph.D. D.Phil.

Vol. XIII, 1796-1800 : Public and Law Department.
Editor : Dr. P.C. Gupta, M.A., Ph.D.

(2) Selections from English Records [Scheme III (a) of the Publication Programme].

Elphinstone Correspondence (Nagpur Period), 1804-08. (Being published by the Nagpur Historical Society, Nagpur).

(3) Records in Oriental Languages [Scheme III (b) of the Publication Programme].

Marathi Letters, 1779-1820. (Being published by the Bharata Itihasa Samshodhaka Mandala, Poona).

Telugu Letters (Being published by the Andhra University).

Hindi Letters. 1787-1820, Vol. I, (Being published by the Allahabad University).

(4) Calendar of Persian Correspondence :

Vol. X, 1792-93. Editor : Dr. B.A. Saletore, M.A. Ph.D. D. Phil.

(5) Index to the Foreign and Political Department Records,

Vol. I, 1756-80.

APPENDIX III

(Vide para 22)

Statement showing the Strength of Officers and Staff of the National Archives of India, New Delhi in the Various Categories With Their Respective scales of Pay

Sl. No.	Designation.	Scale of pay	Perma- nent	Temp- orary	Total	REMARKS.
1	2	3	4	5	6	7
<i>Class I</i>						
1	Director of Archives	1300—60—1600	1	..	1	
2	Deputy Director of Archives	800—50—1200	..	1	1	
3	Asstt. Director of Archives	500—25—600— 40—1000	3	2	5	
			4	3	7	
<i>Class II (Gazetted)</i>						
1	Administrative Officer	530—30—710	..	1	1	
2	Librarian	275—28—500— 30—800	1	..	1	
3	Archivists	350—25—500— 30—680	5	8	13	
4	Microphotographer	Do.	..	1	1	
5	Scientific Officer	Do.	..	1	1	
6	Assistant Engineer	Do.	..	1	1	
7	Technical Officer	Do.	..	1	1	
*8	Senior Superintendent	350—25—500— 30—650.	1	..	1	*Kept in abeyance Administra- tive Offi- cer's post created in lieu of it.
9	Archival Chemist	350—25—500— 30—680	1	..	1	
			8	13	21	

1	2	3	4	5	6	7
---	---	---	---	---	---	---

Class II (Non-Gazetted)

1	Assistant Chemist (Gr. I)	250—10—300— 15—450—25/2 —500	I	I	2
2	Assistant Microphotographer (Gr. I)	Do.	I	..	I
3	Assistant Archivist (Gr. I)	Do.	11	9	20
			<hr/>	<hr/>	<hr/>
			13	10	23

Class III (i) Ministerial

1	Superintendent	275—15—455	I	I	2
2	Assistant	160—10—330	2	..	2
3	Assistant-cum-Cashier	Do.	I	..	I
4	Hindi Assistant	Do.	..	2	2
5	Proof Reader	100—5—125— 6—155—EB— 6—185	I	..	I
6	Stenographer	80—5—120—EB 8—200—10/2— 220	I	I	2
7	Upper Division Clerks	Do.	..	16	16
8	Clerks-cum-Typist	60—3—81—EB 4—125—5— 130	23	9	32
9	Hindi Typist	Do.	..	I	I
10	Gestetner Operator	60—5/2—75	..	I	I
11	Van Driver	Do.	..	I	I

(ii) Non-Ministerial

1	Foreman (Mech.)	200—10—300	I	..	I
2	Assistant Librarian	160—10—350	I	..	I
3	Asstt. Archivist (Gr. II)	160—10—330	23	11	34
4	Assistant Chemist	Do.	3	..	3
5	Assistant Microphotographer (Gr. II)	Do.	2	2	4
6	Photographer (Mech.)	150—7—185— 8—225	..	I	I

1	2	3	4	5	6	7
7	Foreman	125-6-186	..	I	I	
*8	Maulvi	250-10-300	I	..	I	*Kept in abeyance in lieu of one post of Archivist.
	Caretaker	100-8-140- 10-300	I	..		
10	Boiler Operator	100-5-125-6 155-EB-6- 185	..	I		
11	Electrician with 'A' Grade Licence	80-5-120- EB-8-200- 10/2-220.	..	I		
12	Electrician with 'B' Grade Licence	75-3-105-5 -120	..	I		
13	Carpenter	60-5/2-75-3 3-105	..	I	I	
14	Asstt. Foreman	75-3-105-5- 120	..	I	I	
15	Laboratory Asstt.	60-4-120-EB -5-150	2	..	2	
16	Preservation Asstt.	Do.	14	9	2	
17	Photo Assistant	Do.	4	2	6	
18	Mechanics	Do.	2	..	2	
19	Binders	54-2-60-3/2 -75	..	14	14	
20	Special Grade Record	45-2-55-3- 85-EB-4- 105	4	..	4	
	Attendants.		87	77	16.	

Class IV

1	Record Attendants (Gr. I)	40-1-50-2- 60	18	9	27
2	Menders (Gr. I)	Do.	5	..	5
3	Boiler Attendant	Do.	..	I	I
4	Laboratory Attendant	Do.	3	3	6
5	Record Attendant (Gr. II)	35-1-50	17	1	18
6	Menders (Gr. II)	Do.	14	2	16

7	Guards (Gr. I)	. . .	35—1—40	2	..	2	In abeyance.	
8	Guards (Gr. II)	. . .	30—1—35	5	1	6		
9	Helpers	Do.	..	3	3		
10	Peons	Do.	45	37	82		
11	Sweepers	Do.	4	2	6		
				113			59 172	

GRAND TOTAL

Class I			Class II (Gaz.)			Class II (N.G.)			Class III			Class IV		
P. T. Total			P. T. Total			P. T. Total			P. T. Total			P. T. Total		
4	3	7	8	13	21	13	10	23	87	77	164	113	59	172
Staff strength :—Permanent 225												} 387		
Temporary 162														

APPENDIX IV

(Vide para 22)

Statement showing the strength of staff of the Regional Office, Bhopal together with their respective scales of pay.

Sl. No.	Designation.	Scale of pay.	Perma- nent.	Tempy.	Total
<i>Class I—Gazetted</i>					
1	Keeper of Records	500—25—500— 40—1000	1	..	1
			1	..	1
<i>Class II—Gazetted</i>					
2	Archivists	350—25—500— 30—680	..	1	1
3	Preservation Supdt.	Do.	..	1	1
			..	2	2
<i>Class II—Non-Gazetted</i>					
4	Senior Chemist	250—10—300— 15—450—25/2— 500	..	1	1
			..	1	1
<i>Class III—Establishment</i>					
5	Head Clerk	160—10—250	1	..	1
6	Accountant-cum-Cashier	80—5—120—EB —8—200—10/22 —220	..	1	1
7	Stenographer	Do.	..	1	1
8	Upper Division Clerks	Do.	2	2	2
9	Preservation Asstts	60—4—120—EB 5—150	..	2	2
10	Typists & Clerks	60—3—81—EB —4—125—5— 130	2	3	5
11	Binders	54—2—60—5/2 —75	..	2	2
12	Asstt. Archivists (Gr. II)	160—10—330	..	2	2
			5	12	17

Class IV Establishment

1	Daftary	. . .	35—1—50	..	2	2
2	Menders	. . .	Do.	..	4	4
3	Parashes & Sweepers	. . .	30—1—35	..	4	4
4	Watchmen	. . .	Do.	..	2	2
5	Peons	. . .	Do.		4	3
					<u>4</u>	<u>15</u>
						<u>19</u>

GRAND TOTAL

Class I	Class II (Gaz).	Class II (N.G.)	Class II (N.G.)	Class III	Class IV
P.T. Total	P.T. Total	P.T. Total	P.T. Total	P.T. Total	P.T. Total
1 ..	1 .. 2 2 ..	1 1	5 12	17 4	15 19

Total Strength :—

Permanent 10	} 40
Temporary	

APPENDIX V

(Vide para 32)

ORGANISATIONAL SET-UP OF THE DEPARTMENT OF ARCHAEOLOGY

The Headquarters Office of the Director General of Archaeology,
New Delhi.

Director General

Joint Director General

<i>Dy. Director General (Administration).</i>	<i>Deputy Director General (Exploration).</i>	<i>Deputy Director General (Monu- ments).</i>
<i>Archaeological Engineer</i>	<i>Superintendent (Prehistory).</i>	<i>Garden Superinten- dent.</i>
<i>Assistant Superintendent (Prehistory).</i>	<i>Assistant Superinten- dent (Headquarters).</i>	<i>Assistant Superinten- dent (Epigraphy).</i>
<i>Administration Section (Section Officer).</i>	<i>Monuments and Mus- eum Section (Section Officer).</i>	<i>Accounts Section (Section Officer).</i>
<i>O & M and Receipt Section (Section Officer).</i>	<i>Central Archaeological Library (Librarian).</i>	

(a) Photographic Section.

(b) Drawing Section.

II. CIRCLES 9.

1. *North Western Circle, New Delhi.*

*Superintendent.
Assistant Superintendent.
Assistant Engineer.*

2. *Northern Circle Agra.*

*Superintendent.
Assistant Superintendent.*

3. *Mid Eastern Circle, Patna.*

Superintendent.
Assistant Superintendent.

4. *Eastern Circle, Calcutta.*

Superintendent.
Assistant Superintendent.
Assistant Engineer.

5. *Central Circle, Bhopal.*

Superintendent.
Assistant Superintendent.
Custodian Grade I.

6. *South Eastern Circle, Visakhapatnam.*

Superintendent.
Assistant Superintendent.

7. *Southern Circle, Madras.*

Superintendent.
Assistant Superintendent.

8. *South Western Circle, Aurangabad.*

Superintendent.
Assistant Superintendent.
Special Officer.

9. *Western Circle, Baroda*

Superintendent.
Assistant Superintendent.

III. *BRANCHES.* 4.

1. *Garden Branch, Delhi.*

Garden Superintendent.

Branch, Agra.

Assistant Garden Superintendent.

2. *Excavation Branch, New Delhi.*

Superintendent.

3. *Epigraphical Branch (Ootacamund).*

Government Epigraphist.

Superintendent.

Asstt. Superintendent Epigraphy.

4. *Chemical Branch, Dehra Dun.*

Archaeological Chemist.

Assistant Archaeological Chemist, Hyderabad

IV. MUSEUMS 2.

1. *Indian Museum, Calcutta,*

Superintendent.

2. *Central Asian Antiquities Museum, New Delhi.*

Superintendent.

Asstt. Archaeological Chemist.

IV. PROJECTS 3.

1. *Nagarjunakonda Excavation Project.*

Superintendent.

Assistant Superintendent 5.

2. *Temple Survey Project, South Madras.*

Superintendent.

3. *Temple Survey Project, North Bhopal.*

Superintendent.

APPENDIX VI

(Vide para 47)

Statement showing the strength of the officers and staff in the various categories employed in the Department of Archaeology in 1956-57 and 1957-58 together with their respective scales of pay.

Sanction Strength 1956

Class I 48	Class II 12	Class III 673	Class IV 526
---------------	----------------	------------------	-----------------

Sanctioned Strength 1957

Class I 48	Class II 12	Class III 851 (+176)	Class IV 684 (+158)	Remarks
---------------	----------------	----------------------------	---------------------------	---------

DETAILS

Designation of post	Scale	Number of posts	
	Rs.	1956	1957
<i>Class I</i>			
Director General of Archaeology	1,600—2,000	1	1
Jt. Director General of Archaeology	1750 fixed	1	1
Dy. Director General of Archaeology	600—1150 Spl. pay Rs. 200/-	3	3
Archaeological Engineer- Superintendent	600—1150	1	1
Government Epigraphist	600—1150	16	16
Archaeological Chemist	600—1150 Spl. Pay.	1	1
Asstt. Archaeological Chemist	350—850	1	1
Asstt. Superintendent	Do.	23	23
Garden Superintendent	600—1150	1	1
		48	48

Class II

Special Officers	275—850	3	3
Asstt. Engineers	275—850—800/850	3	2
Asstt. Garden Superintendent	275—650	1	1
Custodian	275—800	1	1
Office Superintendent	400—500	1	1
Superintendent Technical	400—500	1	1
Section Officer	275—500	2	2
		<u>12</u>	<u>11</u>

Class III

Categories of post	Scale of pay	St- rength on 1-4-56	St- rength upto -date 1-4-57
		3	4
1. Senior Epigraphical Asstt.	250—500	2	2
2. Excavation Assistant	Do.	1	1
3. Senior Chemical Asstt.	Do.	..	1
4. Analytical Asstt.	Do.	1	1
5. Architectural D/man	250—15—400	..	2
6. Artist	250—500	..	4
7. Senior D/man	250—15—400	..	1
8. Librarian	250—590	1	1
9. Senior D/man	250—500	1	1
10. Head Photographer	Do.	1	1
11. Exploration Asstt.	Do.	1	1
12. Stenographer	175—450+50 - Special Pay.	1	1
13. D/man cum-Artist	175—275	2	2
14. Asstt. Librarian	160—10—350	5	9
15. Surveyor Instructor	160—10—330+ 40 - spl. Pay.	1	1
16. Photographer Instructor	Do.]	1	1
		<u>18</u>	<u>30</u>

	1	2	3	4
17. Assistant		160—10—300—15 —450	3	6
18. Works Asstt.		Do.	2	4
19. Inspecting Accountant		Do.	..	2
20. Works Acctt.		Do.	1	2
21. Exploration Asstt.		Do.	1	1
22. Stenographers		160—10—330	2	2
23. Works Asstt.		Do.	1	1
24. Pottery Asstt.		Do.	3	3
25. Antiquity Asstt.		Do.	1	1
26. Photographer		Do.	5	8
27. Curator		Do.	10	11
28. Asstt. Curator		Do.	..	1
29. Asstt. Numismatist		Do.	..	1
30. Epigraphical Asstt.		Do.	8	10
31. D/man		Do.	8	8
32. Drafts man Surveyor		Do.	2	2
33. Exploration Asstt.		Do.	..	36
34. Surveyors		Do.	1	30
35. Conservation Asstt.		160—10—330	38	39
36. Technical Asstt.		Do.	21	26
37. Custodians		Do.	6	6
38. Chemical Asstt.		Do.	29	34
39. Foresco Mechanic		Do.	1	1
40. Gallery Asstt.		Do.	2	2
41. Site Supervisor		Do.	1	11
42. Anthropolgoes. Asstt.		Do.	1	1
43. Supervisor of works		160—10—250	1	1
44. Works Asstt.		Do.	2	2
45. Head Clerk		Do.	10	11
46. Guide Lecturer		150—275	8	8
47. Driver Mechanic		150—225	3	3
48. Junior Chemical Asstt.		125—185	9	10
49. Sub-Divisional Officer		100—300	1	1
50. Mechanical Supervisor		100—300	1	1
51. Junior Librarian		100—250	3	3
52. Sub-Overseer		100—185	29	32
53. Gallery Asstt.		Do.	1	1
			<u>233</u>	<u>362</u>

	1	2	3	4
54. Driver Mechanic		100—185	11	12
55. Care-taker		Do.	1	1
56. Draftsman		Do.	25	28
57. Technical Asstt. Junior		Do.	1	1
58. Surveyor D/Man		Do.	4	4
59. Head Store Keeper		Do.	3	3
60. Surveyor		Do.	3	13
61. Modeller		Do.	9	14
62. Accountant and Accts. Clerk		80—220	18	19
63. Stenographer		Do.	15	17
64. U.D.C.		Do.	30	39
65. Works Asstt. Senior		Do.	6	6
66. Works Supervisor.		Do.	1	1
67. Photographer		Do.	16	21
68. Junior Gallery Asstt.		Do.	1	1
69. Supervisor		80—4—120	1	1
70. Fieldman		Do.	1	1
71. Bookbinder		75—120	1	1
			<u>380</u>	<u>515</u>
72. Carpenter		75—3—105	3	5
73. L.D.C.+Booking Clerk		60—130	83	91
74. Caretaker		Do.	26	30
75. Photoprinter		60—150	1	3
76. Steno-Typist		60—130+Rs. 20/- spl. Pay.	1	2
77. Junior works Asstt.		60—130	8	10
78. Caretaker-cum-guide		Do.	..	1
79. Laboratory Asstt.		Do.	6	6
80. Asstt. Draftsman		60—150	10	10
81. Store-Keeper		60—5/2—75—3—105	1	1
82. Mistri		Do.	3	3
83. Fitter		Do.	2	2
84. Blacksmith		Do.	1	1
85. Photoprinter		60—5/2—75	11	15
86. Mason		Do.	29	30
87. Khansaman at Mandu in M.P.		Do.	..	1
88. Fireman		Do.	57	61

	1	2	3	4
89. Marksman		60—5/2—75	19	21
90. Asstt. Modeller		Do.	1	5
91. Mechanical Asstt.		Do.	1	1
92. Engraver		Do.	2	2
93. Carpenter		Do.	..	1
94. Asstt. Mechanic		Do.	1	1
95. Engine-Driver		Do.	..	1
96. Do.		40—2—60—5/2— 75	4	4
97. Chhowdhary		Do.	16	17
98. Store-keeper		40—20— 60	9	11
			<u>675</u>	<u>851</u>

CLASS IV

Sl. No.	Category post	Scale of pay	St- rngth on 1-4-56	Upto- date st- rngth
1.	Supervisor	40—2—60	1	1
2.	Binder	Do.	1	1
3.	Mechanic	Do.	2	2
4.	Record Sorter	Do.	..	1
5.	Daftry	35—1—50	17	23
6.	Jamadar	Do.	14	14
7.	Head Monument Attendant	Do.	4	4
8.	Head Attendant	Do.	3	4
9.	Head Monument Cleaner	Do.	2	2
10.	Head Garden Attendant	Do.	2	2
11.	Head Mali	Do.	9	9
12.	Head Guard	Do.	1	1
13.	Guards	30—1/2—35	2	2
14.	Peons	Do.	125	131
15.	Farash	Do.	3	3
16.	Attendant	Do.	152	290

	1	2	3	4
17. Motor Attendant		30—1/2—35	12	13
18. Survey, Pottery and Store Cooly .		Do.	6	6
19. Waterman and water cooly . . .				
20. Monument Attendant		Do.	1	2
21. Sweeper		Do.	2	2
22. Garden Attendant, Mali		Do.	32	35
Gardeners and Mali Mazdoors .			27	27
23. Watchman, Chowkidar, and Night Chowkidar.		Do.	101	102
24. Khidmatgar		Do.	1	1
25. Bhishti		Do.	6	6
			<u>526</u>	<u>684</u>

APPENDIX VII

(Vide para 55)

ORGANISATIONAL SET-UP OF THE DEPARTMENT OF ANTHROPOLOGY

AS ON 1-4-1957

DIRECTOR

DEPUTY DIRECTOR

HEAD QUARTERS

CULTURAL ANTHROPOLOGY DIVISION

Social Anthropology Section | Ethnography Section (including Gallery) | Linguistics Section | Psychology Section

Anthropologist | Anthropologist | Anthropologist | Asstt. Anthropologist

PHYSICAL ANTHROPOLOGY DIVISION
SUPERINTENDING ANTHROPOLOGIST

Human Biology Section (including X Ray) | Morphology Section (including Vertebrate Zoology and Anatomy)

Anthropologist | Anthropologist | Asstt. Anthropologist | Anthropologist | Bio-Chemist

Somatology Section | Bio-Chemist Section

AUXILIARY DIVISION

Training Scheme | Statistical Section | Administrative Section | Library Section | Photography Section

Anthropologist | Asstt. Anthropologist | Administrative Officer | Librarian.

OUTSIDE STATIONS

Andaman and Nicobar Section | Assam Station | Nagpur Station

T. Corr. Section

Anthropologist | Anthropologist | Supdtg. Anthropologist

APPENDIX VIII

(Vide para 56)

Note giving in brief the details of the work done by the three Regional Research Stations of the Department of Anthropology during the years 1954-55, 1955-56 and 1956-57

ANDAMAN & NICOBAR STATION

1955-56

1. The skeletal and other human remains that were collected during the previous investigations were identified, treated and restored as far as possible.
2. Few facial masks were taken from Car Nicobares for Somatological study.
3. Linguistic and social anthropological study of the Onge of Little Andaman Island.

1956-57

1. Work in Little Andamans was continued, specially on the local language.
2. Detailed study in social anthropology was continued in Car Nicobar Island.
3. Human Biology Section was started and genetic studies were undertaken in Car Nicobar Islands.

1957-58

1. The study of the Nicobarese dialect has been undertaken.

ASSAM STATION

1955-56

1. Study of Pnar (Khasi) cultures in all aspects with special reference to the changes in their way of life due to contact with the forces of the civilization, was undertaken.
2. A paper has been prepared on "Beh-Bieng-Khalem festival of Pnars of Jaintia Hills".
3. A paper has been prepared on "Pom Blang (Boat-killing) festival of Khasi".
4. The study of war cultures in all aspects with special reference to the changes due to the impact of civilization, was undertaken.

1956-57

1. Study of Chandi Puja with related Socio-religious ceremonies among the War of Shella Village (Khasi Hills), was undertaken.
2. Study of Pnar culture in all aspects was continued.

1957-58

1. Study of war cultures in all aspects, is still in progress.
2. Study of Lynggam cultures of western part of Khasi and Jaintia Hills Dist. was undertaken. Data on all aspects except political organisation and Folklore has been collected.
3. Study of Pnar hand-made pottery in the Jaintia Hills of Assam, was undertaken.

NAGPUR STATION

1955-56

1. Two Research Projects in Mandla and Bastar District were undertaken to evaluate the process of cultural change in the tribal population.
2. Detailed tribal map of Madhya Pradesh was prepared.

1956-57

1. A multi-caste village in Vidarbha was selected for a comprehensive sociological community study.
2. The same type of sociological community study has also been taken up in a North M. P. village.
3. A monograph on Ollari, a Dravidian Speech, was prepared.
4. A monograph on the Korku language was prepared.
5. A dictionary of Kollarian Language was being prepared.
6. Notes on ethnic and linguistic composition of South Bastar tribal language were prepared.
7. About 1500 books were bought for the Library.

1957-58

1. Analysis of material on cultural factors in rural health and hygiene was continued.
2. Tabulation and analysis of M.P. Census data on tribal groups district-wise was continued.
3. Maps and sketches of two villages and house-types were prepared.
4. Analysis of Korku language is being continued.
5. Tribal maps and sketches of old Madhya Pradesh which were started before reorganisation of States were completed.

APPENDIX IX

(Vide para 65)

LIST OF MUSEUMS IN INDIA

Central Government Museums

1. National Museum of India, New Delhi.
2. National Gallery of Modern Art, New Delhi.
3. Indian War Memorial Museum, Red Fort, Delhi.
4. Delhi Fort Museum, Delhi.
5. Central Asian Antiquities Museum, New Delhi.
6. Archaeological Museum, Nalanda.
7. Nagarjunakonda Museum, Nagarjunakonda.
8. Museum of Archaeology, Sanchi.
9. Sarnath Museum, Sarnath.
10. Kondapur Site Museum, Kondapur.
11. Gumti Gate Museum, Gour, Malda.
12. Fort Museum, Fort St. George, Madras.
13. Khajuraho Museum, Khajuraho.
14. Hampi Museum, Hampi.
15. Amarvati Museum, Amarvati.

State Government Museums

1. Central Museum, Gwalior.
2. Central Museum, Indore.
3. State Museum, Dhubela (Naogaon)
4. State Museum, Raipur.
5. Jamna Bagh Museum, Gwalior.
6. State Museum (Orissa), Bhubneshwar.
7. Assam State Museum, Gauhati.
8. Assam Cottage Industries Museum, Gauhati.
9. Assam Forest Museum, Gauhati.
10. Government Museum, Madras.
11. Government Museum, Pudukkottai.
12. Tanjore Art Gallery, Tanjore.

13. Padmanabhapuram Palace and Museum.
14. The Museum and Picture Gallery, Baroda.
15. The Lady Wilson Museum, Dharampur.
16. Shri Bhawani Museum, Audh.
17. The Museum at Kolhapur.
18. The Central Museum, Nagpur.
19. The Museum Junagadh.
20. The Museum Jamnagar.
21. The Museum Rajkot.
22. The Museum Prabhas Patan.
23. The Museum Bhuj.
24. Central Museum, Jaipur.
25. Rajputana Museum, Ajmer.
26. Sardar Museum, Jodhpur.
27. Ganga Golden Jubilee Museum, Bikaner.
28. State Museum, Bharatpur.
29. Alwar Museum, Alwar.
30. Museum Kotah.
31. Victoria Hall Museum, Udaipur.
32. Archaeological Museum, Jhalawar.
33. Archaeological Museum, Amber.
34. Punjab Government Museum, Simla.
35. Pepsu Museum. Patiala.
36. Mysore Government Museum, Bangalore.
37. Shrimanthi Bhavan, Mangalore.
38. The Museum of Local Antiquities, Chitaldurg.
39. Government Museum. Trivandrum.
40. Cochin State Museum. Trichur.
41. Sri Chitralayam, Trivandrum.
42. Museum of Antiquities and Palace Padmanabhapuram.
43. Archaeological Museum and Picture Gallery. Trichur.
44. Shri Pratap Singh Museum. Srinagar.
45. Government Industrial Museum, Calcutta.
46. The state Museum, Lucknow.
47. Archaeological Museum, Mathura.
48. Hyderabad Museum, Hyderabad.
49. Health Museum, Medical Department, Andhra Pradesh.
50. Museum Alampur.
51. Museum at Anantapur.
52. Bhuri Singh, Chamba.
53. Patna Museum, Patna.
54. Bodh Gaya Museum, Bodh Gaya.

University Museums

1. Anthropology Tribal Cultural Museum, Gauhati University, Gauhati.
2. Commerical Museum Gauhati University, Gauhati.
3. Education Museum, Gauhati University, Gauhati.
4. The Archaeological Museum of the M.S. University, Baroda.
5. Ashutosh Museum of Indian Art, Calcutta University, Calcutta.
6. The Allahabad University Museum, Allahabad.
7. Bharat Kala Bhavan Banaras, Hindu University, Banaras.
8. Science Museum, Osmania University, Hyderabad.
9. Museum attached to the Zoology Deptt. of Sri Venkatesware University.

Other Museums

1. The Prince of Wales Museum of Western India, Bombay.
2. Prince Albert Museum, Bombay.
3. The Lord Reay Maharashtra Industrial Museum, Poona.
4. The Barton Museum, Bhavnagar.
5. The Museum of the Bharat Itihas Sanshodhak Mandal, Poona.
6. Museum of the Deccan College of Post Graduate Research Institute, Poona.
7. Winchester Museum, Surat.
8. Museum of the Rajwade Samshodhan Mandal, Dhullia.
9. Amreli Museum, Amreli.
10. The Museum at Vallabh Vidyanagar, Distt. Kaira.
11. The Gujarat Vidya Sabha, Ahmedabad.
12. The Textile Museum, Ahmedabad.
13. The Museum of Indian Historical Research Institute, St. Xavier's College, Bombay.
14. Museum Silear.
15. Museum at Bundi.
16. Museum of Kannada Research Institute, Dharwar.
17. Archaeological Museum, Bijapur.
18. Shri Moolam Shastiabdapurti Industrial Museum, Trivandrum.
19. Dogra Art Gallery, Jammu.
20. Hamiltonians Museum Midnapore.
21. Jharagram K. K. Institution Museum.
22. Bangiya Sahitya Parishad Museum, Bankapura.
23. Natural History Museum, Darjeeling Town.
24. Malda Museum, Malda.
25. Rishi Bankim Library and Museum, Kanthalpara, P. S. Naihati.
26. Museum of Bangiya Sahitya Parishad, Calcutta.
27. Victoria Memorial Hall, Calcutta.

28. Indian Museum, Calcutta.
29. Municipal Museum, Calcutta.
30. Anatomical Museum, Medical College, Calcutta.
31. Pathology Museum, Medical College, Calcutta.
32. Serampore College Museum, Calcutta.
33. Sarada Charan Museum, Hooghly.
34. Municipal Museum, Allahabad.
35. Gurukul Museum, Hardwar.
36. The Hindi Bhawan, Kalpi.
37. Salarjung Museum, Hyderabad.
38. Regional Museum of College and Small Scale Industries, Krishna District Board.
39. Andhra Medical College Museums (a) Pathology Museum (b) Botany Department Museum, (c) Anatomy Museum and (d) Social and Preventive Medicine Department Museum, Visakhapatnam.
40. Guntur Medical College Museums (a) Pathology Department (b) Anatomy Department (c) Forensic Medicine Deptt. and (d) Hygiene Department.

APPENDIX X
(*vide* para 69)

Organisational set-up of the National Museum in accordance with Gwyer Committee Report.

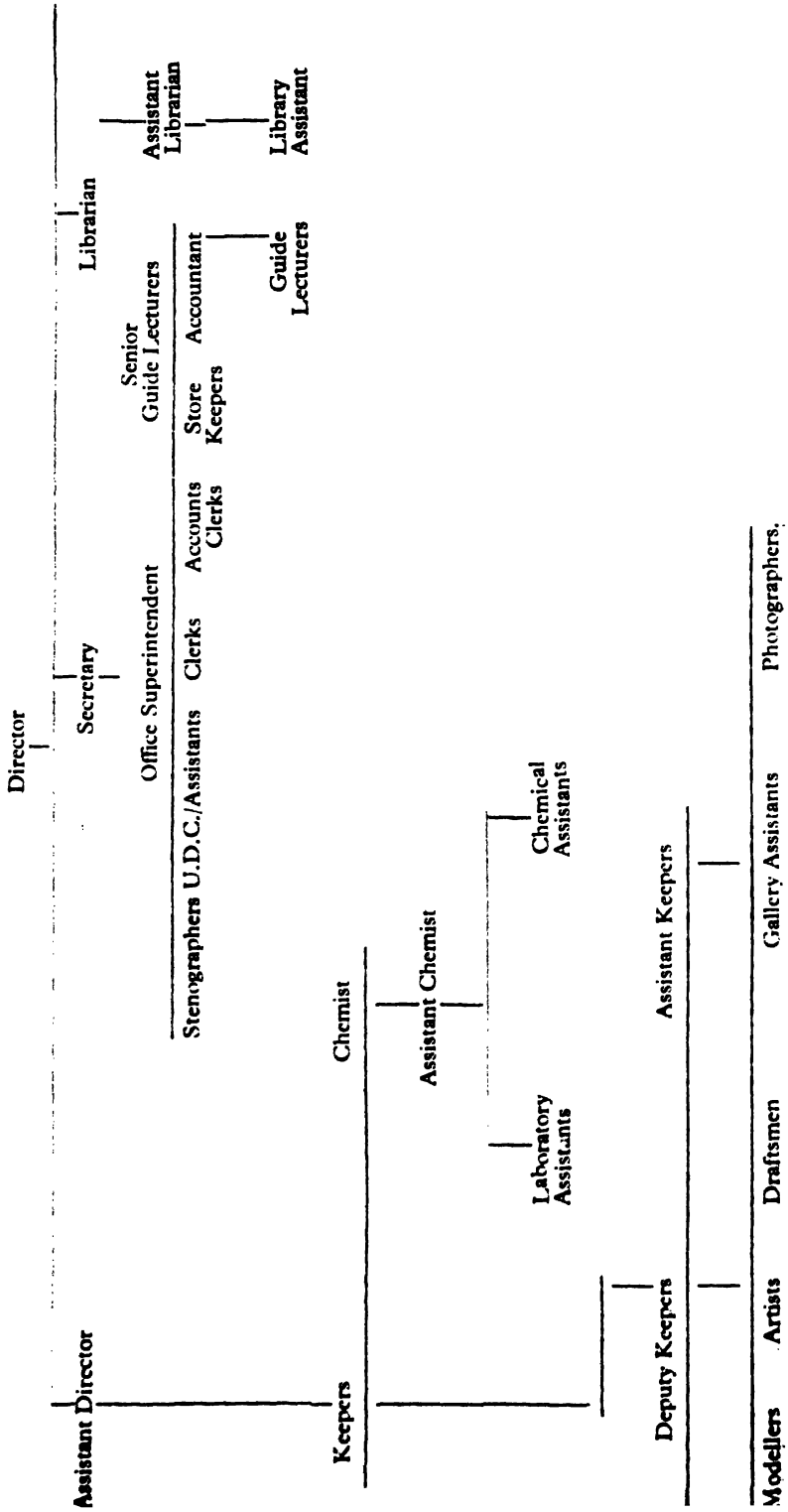

APPENDIX XI

(Vide para 83)

Statement showing details of the Budget estimates and actual expenditure of the National Museum.

1954-55	Original Grant	Final Grant after su- rrender	Actuals
	Rs.	Rs.	Rs.
Pay of Officers	50,000	5,604	3,117
Pay of Establishment	63,100	37,700	37,540
Allowance & Honorarium	86,000	31,000	30,730
Contingencies	50,900	50,900	49,434
TOTAL	2,50,000	1,25,504	1,20,821
1955-56			
Pay of Officers	50,000	22,240	23,839
Pay of Establishment	63,100	40,550	40,446
Allowance & Honorarium	86,000	37,380	36,383
Contingencies	50,900	1,03,600	87,652
TOTAL	2,50,000	2,03,770	1,88,320
1956-57			
Pay of Officers	60,000	21,740	19,841
Pay of Establishment	63,000	44,380	44,479
Allowance & Honorarium	90,000	36,350	34,987
Contingencies	87,000	76,800	58,112
TOTAL	3,00,000	1,79,270	1,57,419

APPENDIX XII

(Vide para 96)

Organisational Chart of the Indian Museum, Calcutta.

As on 1st, April, 1955

INDIAN MUSEUM

Trustees

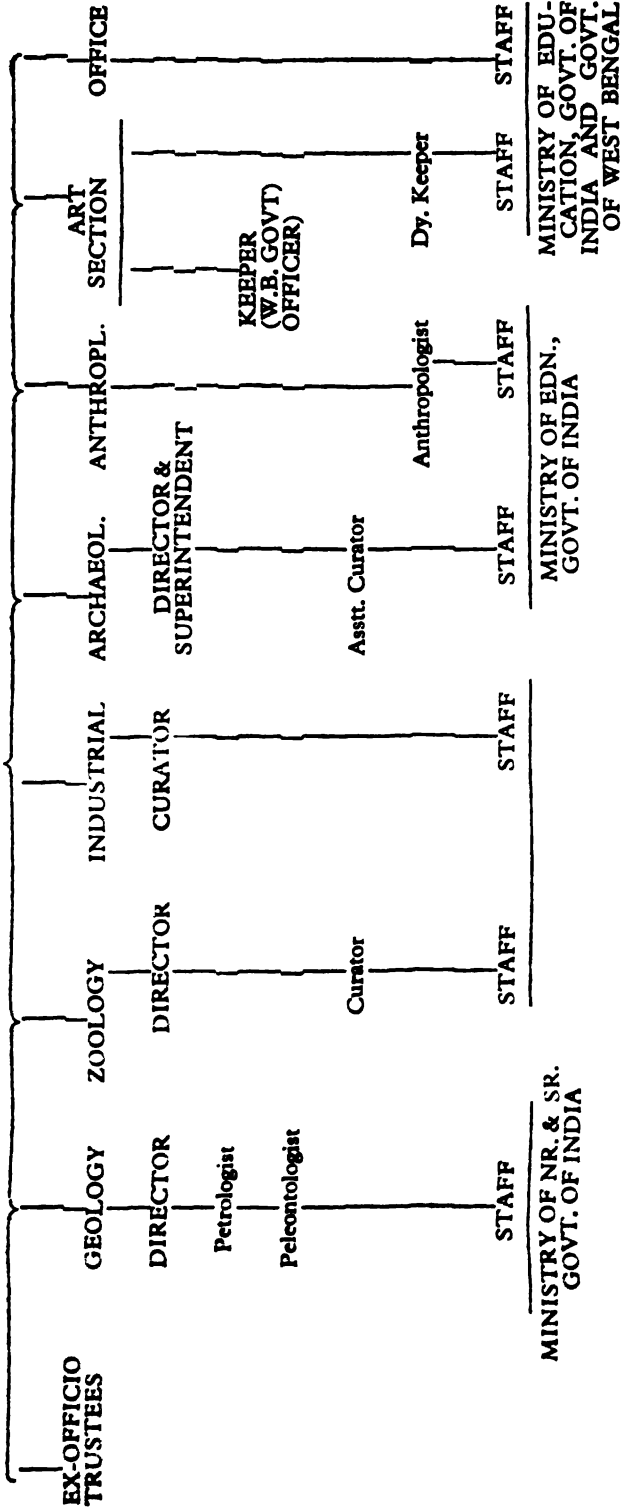

APPENDIX XIII

(Vide para 111)

Organisation charge of the National Library, Calcutta.

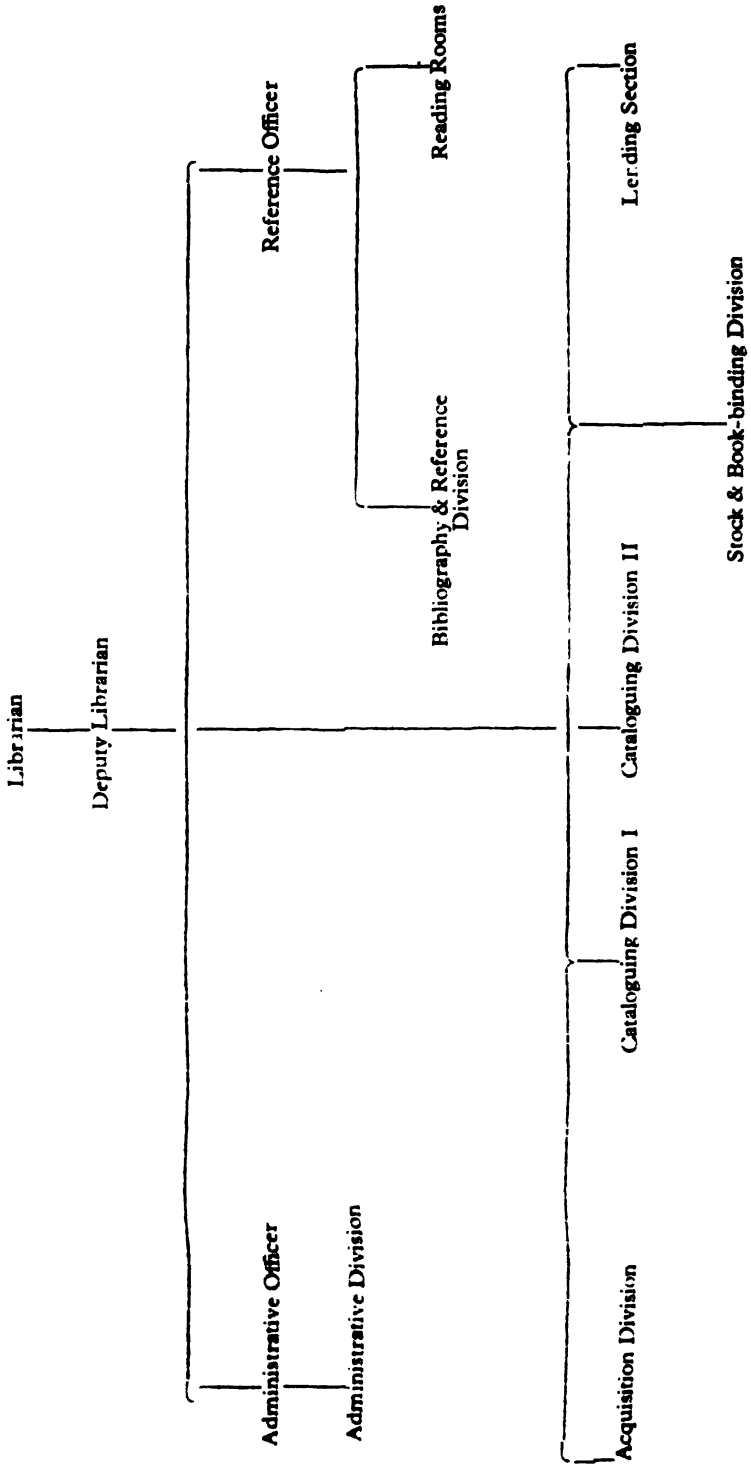

APPENDIX XIV

(*Vide para 121*)

A brief Resume of the Important Activities of the National Library.

The following are the important activities of the Library:

(i) *Compilation of the Indian National Bibliography*

The scope of the Indian National Bibliography is nothing less than the scientific record of all the publications in India in all the languages, recognised by the Constitution, both official and non-official. The official publications will include not only Central Government publications but also the State Government publications. It will be a classified Bibliography in the roman script with an index both according to language and in the Dictionary manner.

(ii) *Exhibition*

The Library periodically arranges a number of very important exhibitions not only educative to the ordinary citizens but also to students and scholars.

(iii) *Documentary*

The Library co-operated with the Ministry of Information and Broadcasting in making a Documentary of the National Library which has been released all over the country and copies of which were sent to several Indian Embassies abroad. This Documentary was designed to let the public know as to the resources and functions of the Library.

(iv) *Library Training*

The Library has been assisting the Calcutta University all these years in running the Diploma Classes in Librarianship. The students of the University are coming every year for Bibliographical study to this Library. The Library has offered facilities to the Bengal Library Association for the running of a full-time summer course as well as a year-long week-end course of Librarianship courses. The practical training is also given to nominees of State Governments and institutions.

APPENDIX XV

Statement showing the summary of conclusions/recommendations

Serial No.	Reference to Para No.	Summary of conclusions/recommendations
1	2	3
1	2	The Committee are of the opinion that it is not necessary to have any division of the Department of National Archives of India on the basis of language.
2	2	The Committee note with surprise that although several ex-princely States have valuable old records of considerable historical value, only Bhopal should have been singled out for starting a Regional Records Office.
3	5	The Committee suggest that an Advisory Committee consisting of suitable non-officials may be formed to advise the Director of Archives in making purchases of historical manuscripts.
4	6	The Committee note with regret that only one Union Territory should have set up a Regional Records Survey Committee. They suggest that such Survey Committees should be set up in each of the Union Territories. The Committee also suggest that the States which have not yet set up Regional Records Survey Committees should be persuaded to set up such Committees as early as possible so that the National Archives could acquire and make use of any archives or historical manuscripts which may come to light through the efforts of those Committees.
5	7	The Committee suggest that a consolidated list of individuals, families and institutions having valuable manuscripts in their possession should be published for the benefit of research scholars.
6	8	The Committee were given to understand that the efforts to acquire private archives had not so far been very successful. The Committee suggest that suitable steps may be taken to evoke a better

1	2	3
		response from the parties in possession of such valuable records. A national appeal through the press might yield some result. The Regional Survey Committees would be considerably useful in this respect.
7	9	As the number of unbound papers in the National Archives of India is enormous, the Committee suggest that a systematic programme for binding should be undertaken by the Department and a target date fixed for the completion of this work.
8	9	The Committee suggest that a central organisation on the same lines as the National Archives of India should be set up to collect and take charge of valuable non-archival manuscripts lying scattered all over the country in the various museums, research institutes, Bhandars etc. and also be responsible for proper classification, preservation and cataloguing of such manuscripts as well as for the publication of suitable documents therefrom. This organisation should also provide suitable facilities to the research scholars to delve into such material collected for purposes of research.
9	9	The Committee regret to learn that a file issued by the National Archives of India in 1926 is still outstanding and that it had not been possible to trace the document so far. They also regret to learn that no registers of the files issued are available for the period prior to November, 1956. The Committee suggest that circumstances leading to this state of negligence should be investigated and responsibility fixed to avoid recurrences. They also suggest that steps should be taken to make out a list of all the files issued from the National Archives, and also to regain custody of them.
10	10	The Committee suggest that a procedure of a periodical review for old records with the object of weeding them out, if they have outlived their utility might be evolved so that some of the much needed space for ever-increasing records might become available.
11	11	The Committee hope that the work of recasting the Research rules will be expedited. The Committee suggest that the rules regarding the availability of records should be liberalised and all records pertaining to pre-Independence era should be declared as 'open', some authority being retained for making exceptions.

1	2	3
12	12	The Committee suggest that the time lag allowed in printing and publication of theses submitted by scholars working in National Archives should be reduced from three years to one year.
13	12	The Committee suggest that suitable non-officials may be associated with the Committee for the final selection of candidates for the award of fellowships.
14	12	As regards the selection of subjects for research, the Committee suggest that as far as possible the subject of research should be intimately connected with the material treasured in the National Archives of India.
15	12	The Committee suggest that steps should be taken to improve co-ordination between the records and the research work and to make suitable arrangements for the publication of the theses produced by scholars.
16	13	The Committee do not consider the explanation given by the Ministry of Education for the functioning of the hydraulic press after about six years of its receipt in the National Archives as satisfactory and observe with regret that if sufficient care and interest had been taken in the matter and if timely advice had been obtained from the experts in the field, this abnormal delay in the functioning of the press could have been avoided.
17	14	The Committee welcome the scheme to supply free on quasi-permanent loan, micro-film copies of rare manuscripts to the four institutions mentioned in para 14 and also suggest that the advisability of gradually extending it to other institutions and to wider ranges of important records should be examined.
18	15	The Committee were informed that 500 copies of each publication brought out by the National Archives of India were printed and it was now intended to print 750 copies of all publications. The Committee suggest that a larger number of copies should be printed as these publications are of high research value, based on authentic records and will be useful to the various libraries and research institutions in the country. The Committee suggest that the distribution list of these publica-

1

2

3

tions should be suitably revised to ensure that maximum benefit is derived by as many agencies as possible. All the libraries of the Universities, colleges and districts should be included in that list.

- 19 16 The Committee suggest that if the scheme for the compilation of a National Register of Records is formulated on the lines of the History of Freedom Movement in India and the Revision of the Gazeteers, and the Central Government promise to the State Governments a substantial grant-in-aid to prepare the scheme, it is likely that the States may carry it out under the general guidance and supervision of the Central Government. A Central Committee and State Committees may be established for the scheme which may be spread over a number of years, depending on the availability of funds for the purpose.
- 20 17 The Committee suggest that the National Archives should formulate a scheme for publishing extracts of important documents on connected subjects, giving facts, history, etc., about a particular development.
- 21 18 The Committee suggest that the three months' short course of training in Archives Keeping conducted by the National Archives of India should be thrown open to the general public.
- 22 18 The Committee suggest that the written test for the selection of candidates for the award of stipends for one year's Diploma Course should be held at the time of their joining the training course and not two months after as at present.
- 23 18 The Committee consider that it would be worthwhile having a regular scheme for training in Archives, something like a training School for which there should be proper publicity and to which even non-government employees may be admitted. The trainee should, on the completion of the course, be awarded a diploma or certificate. The Committee also suggest that the number of trainees should be larger than at present in order to meet the needs of government offices and non-official bodies. They further suggest that follow-up information about outsiders who have taken the training should be maintained.

-
- | 1 | 2 | 3 |
|---|---|---|
|---|---|---|
-
- 24 19 The Committee suggest that a classified catalogue of the material collected for writing the History of Freedom Movement should be published so that it could be made use of by scholars and historians.
- 25 20 The Committee were informed that Dr. Tara Chand had been appointed Narrator to write the History of Freedom Movement. The Committee suggest that it would be of advantage if a Committee of Advisers was appointed to assist the narrator. The Committee of Advisers may consist of persons who were associated with the Freedom Movement and know the various phases of the movement. The Committee are of the view that the work relating to the History of Freedom Movement has already been considerably delayed and should be expedited as much as possible.
- 26 21 The Committee understand that the material collected for writing the History of Freedom Movement by the Board of Editors is so voluminous that it may not be possible to publish a substantial portion of it. The Committee, however, suggest that suitable selections from the material should be properly documented and published.
- 27 23 The Committee suggest that the Officer of the National Archives of India who has been sent abroad for training in the latest scientific methods of repair and binding should on return be able to train the staff and help in setting up the suggested Training School.
- 28 23 The Committee observe that there is almost a stream of people going abroad one after the other to learn one thing or other and that there appears to be no systematic policy in this regard. The Committee consider that if it is necessary to get more up-to-date training abroad, a regular scheme should be drawn up according to which the best available persons in the country should be selected and sent abroad for training. The Committee suggest that having deputed somebody for training abroad, on his return, he should be asked to impart his training to many others in the country by conducting a class or a course so that it might not be necessary every time to send somebody or other for the same training. The Committee further suggest that the persons trained abroad should then try to keep

- themselves in touch with whatever is happening outside by way of exchange of literature etc. The Committee are of the opinion that some such arrangement will eventually lead to self-sufficiency in technical personnel in this field.
- 29 25 The Committee are not convinced of the justification for spending Rs. 40 lakhs in constructing additional accommodation for the National Archives.
- 30 26 The Committee regret to learn that no facilities were provided in Record Office Bhopal until recently for research scholars to consult records. The Committee were told that no facilities could be offered because there was no research room in the branch office. A room for the purpose has now been made available. The Committee would like to stress that whenever any such record office is opened it is important that adequate facilities for research should be simultaneously made available as otherwise an important purpose behind the opening of regional record offices is defeated.
- 31 27 The Committee observe that due to lack of adequate resources, several State Governments are not in a position to take proper care of historical monuments and records other than those declared as of national importance. The Committee suggest that the feasibility of transferring the item 'ancient and historical monuments and records other than those declared by or under law made by Parliament to be of national importance' from the State List to the Concurrent List of the Seventh Schedule to the Constitution of India may be examined.
- 32 28 The Committee are of the view that it would be desirable to have five Regional Archives, one each in the South, North, East, West and in the Centre of the country so as to cater to the needs of the various parts of the country. They suggest that the advisability of formulating such a plan now, although it may take some time to materialise, may be examined. The Committee would also suggest that some palaces of the former princes which might be available could perhaps be used for the proposed Archives.
- 33 29 The Committee suggest that in addition to the National and proposed Regional Archives, some of the universities, libraries or museums might also be developed as second or third grade archives.

- | 1 | 2 | 3 |
|----|----|---------------------------------------------------------------------------------------------------------------------------------------------------------------------------------------------------------------------------------------------------------------------------------------------------------------------------------------------------------------------------------------------------------------------------------------|
| 34 | 32 | The Committee note that two Circles of the Department of Archaeology <i>viz.</i> , North Western Circle at New Delhi and Northern Circle at Agra are situated at close proximity. The Committee suggest that the position regarding the existing Circles should be reviewed to see whether a more rational distribution of the existing Circles is feasible from the point of view of the workload and the area to be covered. |
| 35 | 34 | The Committee suggest that the Department of Archaeology should take steps to have the list of monuments declared as of national importance printed early. This list can then be amended from time to time. |
| 36 | 35 | The Committee are given to understand that the States of Uttar Pradesh, Andhra Pradesh Mysore Kerala, Orissa and West Bengal have passed legislation to look after such monuments in their areas as are not of national importance. The Committee would like the Ministry to take up the matter with the other States with a view to similar legislation being enacted. |
| 37 | 36 | The Sub-Committee of the Estimates Committee which visited Agra were sorry to note that the gardens of the Taj were in a somewhat neglected state. The Committee would like the Department to pay greater attention to this unique monument of international fame. |
| 38 | 37 | In view of the fact that the ground covered in exploration work is as yet totally inadequate, the Committee suggest that efforts should be made to increase the provision under this head and to step up the tempo of work. |
| 39 | 38 | The Committee suggest that instead of going into problems of selection of sites for excavation and the allotment of priority in an isolated manner, it would be desirable to have a complete survey of all the potential sites and then to fix priorities after full consideration of all the sites. It would be useful to draw up a perspective plan for the purpose in consultation with the Central Advisory Board of Archaeology. |
| 47 | 39 | The Committee feel that some foreign and International organisations may be interested in Lothal, Nagarjunakonda and other such civilizations in |

I

2

3

India and it might be possible to have for these projects some International co-operation, technical knowledge and financial resources. The Committee, therefore suggest that the possibility of negotiating such co-operation and assistance with some international agency which might be interested in this sphere, for a wide-spread programme of archaeological excavations, may be explored.

- 41 40 The Committee suggest that some of the site museums should, with advantage, be merged with the local museums. They also suggest that a site museum should be established at Lothal.
- 42 40 The Committee hope that the work of revision of the draft of the National Directory of Museums in India will be expedited.
- 43 41 The Committee suggest that it may be examined as to how the guest house at Sarnath which was constructed at Government expense by the Ministry of Transport in connection with the Buddha Jayanti Celebrations, and which is now hardly being patronised can best be utilised.
- 44 42 The Committee suggest that the number of copies of the publication 'Corpus Inscriptionum Indicarum' may be suitably increased in future and copies thereof supplied to all Museums, Universities and other important research libraries in the country.
- 45 43 The Committee suggest that the number of picture post-cards to be printed by the Department of Archaeology may be increased to meet the demand.
- 46 44 The Committee learn is that the Department is experiencing difficulty in the procurement of art paper for its publications. The Committee are of the view that instead of wholly relying on imported paper, the indigenous production of art paper of the requisite standard should be encouraged, and suggest that the Ministry of Commerce and Industry should look into this matter.
- 47 45 The Committee suggest that the work of cataloguing the manuscripts in the Delhi Fort Museum and in the Central Archaeological Library should be completed and that a list of the manuscripts should be published as early as possible.

1	2	3
48	46	The Committee suggest that training facilities in the field of Archaeology in the Department of Archaeology may be expanded so as to meet the requirements of universities.
49	46	The Committee consider that it would be desirable to set up the proposed school of Archaeology so that training could be given not only to those who are in the Department but also to others and suggest that the proposal may be finalised early. The proposed school should arrange for advanced courses in the various subjects connected with Archaeology.
50	47	The Committee suggest that the increase in the class III and class IV posts in the Department of Archaeology may be carefully examined by the O & M Division to see whether the increase in the staff is commensurate with the increased activities undertaken.
51	51	The Committee suggest that the question of strengthening the departments of Archaeology of the Universities and of other institutions engaged in archaeological research work should be examined, and proper schemes should be formulated, publicised and Universities and institutions be asked to take them up with the aid of grants.
52	52	The Committee hope that Central Government would impress on the State Governments of Punjab, Bihar, West Bengal and Assam which have not yet set up their Departments of Archaeology the necessity of taking immediate steps to establish the departments.
53	53	The Committee feel that there does not appear to be much justification for the Headquarters of the Department of Archaeology etc. to be in Delhi. From a broad national point of view, the Committee consider that the multifarious activities of the Government should be spread out evenly in the different parts of the country. For this reason and in order to relieve pressure on accommodation in Delhi, the Committee suggest that the headquarters of the Archaeological Department should be shifted to some place outside Delhi where suitable accommodation may be available.
54	56	The Committee feel that the activities of the Andaman and Nicobar station of the Department of Anthropology during the last three years have been rather sluggish.

1	2	3
55	56	The Committee suggest that priority be given to the study of tribes about whom nothing or very little is known at present and of tribes which have been gradually declining in number or are stagnant.
56	58	The Committee regret to note that inspite of the fact that the Department of Anthropology has been running a scheme of advanced training since 1946, it has not been able to meet its requirements of technical staff in full. The Committee fail to understand why this shortage of trained staff should persist and they suggest that the matter should be carefully investigated to see whether the personnel trained by the Department, and particularly those who were given stipends are serving in the Department or whether they have been allowed to join other services. They also suggest that the requirements of the technical personnel during the Second and Third Plans should be properly assessed and steps taken to train up the required number of personnel.
57	59	The Committee are glad to learn that the publications of the Department of Anthropology are distributed in the various countries on an exchange basis. The Committee suggest that all Universities, colleges, important libraries and such other instituitors should be on the mailing list.
58	59	The Committee suggest that the Department should bring out annual reports giving a survey of the important activities of the Department of Anthropology on the same lines as is being done by the Department of Archaeology.
59	60	The Committee are not aware whether the results of survey and researches made by the staff of the Department of Anthropology which are published in the Bulletins, Memoirs etc., are utilised by the Government Officers who are called upon to serve in the tribal areas. They suggest that all Government officers who are required to serve in the tribal areas should be required to read relevant literature published by this Department and familiarise themselves adequately with the habits, customs, social attitudes, psychological a reactions etc. of the tribes.
60	61	The Committee suggest that with a view to encouraging officers who might be called upon to serve in

1	2	3
		tribal areas to learn tribal languages, the advisability of reviving the language allowances may be considered.
61	62	<p>The Committee suggest the following for a well integrated programme in dealing with tribal population :</p> <p>(a) A regular training of anthropology for Administrators in tribal areas.</p> <p>(b) Officers who know tribal languages and who have done a course in Anthropology to be preferred for posting in tribal areas.</p> <p>(c) Anthropology to be one of the subjects on the I. A. S. Training Course.</p>
62	63	<p>The Committee understand that at present there is no co-ordination maintained between the Department of Antrhropology and the Ministry of Information and Broadcasting in regard to the exhibition of films made by the former about the life of the various Indian tribes. The Committee consider that some of these films could perhaps be utilised with advantage by the Ministry of Information and Broadcasting for educational purposes. They therefore suggest a closer collaboration between this Department and the Ministry of Information and Broadcasting in this regard.</p>
63	64	<p>The Committee recommend that the existing University Departments of Anthropology may be strerghened and other Universities persuaded to create Departments of Anthropology so as to stimulate interest in the subject.</p>
64	69	<p>The Committee are of view that the proposed staff for the National Museum is on the high side and suggest that the position may be examined in consultaton with the O & M Division.</p>
65	70	<p>The Committee agree with the recommendation made by the Gwyer Committee that the National Museum should, in accordance with the successful precedent of the British Museum, be set up as an autonomous body as soon as possible.</p>
66	72	<p>The Committee are surprised to learn that in spite of the efforts of the Ministry through the U.P.S.C. and directly it has not been possible to recruit the</p>

1

2

3

Assistant Director for the National Museum. The Committee are of the opinion that for the proper development of the Museum, it is necessary that the post of the Assistant Director should be filled as clearly as possible.

- 67 72 The Committee understand that eventually it is proposed to appoint a Director in charge of the National Museum and that this post has not yet been formally created because of the difficulty of getting an eminent museologist for this purpose. The Committee suggest that a suitable person may be selected for this purpose and then given intensive training in India or abroad.
- 68 74 In view of the shortage of properly trained personnel for the National Museum, the Committee consider that it is essential that a high priority should be given to the training of those who are already working in the Museums and the training of additional personnel. The Committee suggest that a scheme should be drawn up to impart training to the entire staff of the National Museum. The scheme should be extended to other Museums in the country early.
- 69 75 The Committee suggest that rather than keeping a large percentage of exhibits in godowns, some systematic arrangements may be devised under which some of the exhibits can be lent to the State Museums so that people might benefit from them. The Committee also suggest that the National Museum should use its goods offices to have the replicas made of the selected exhibits of each Museum so that they can be distributed to all the important Museums in the country.
- 70 76 The Committee regret to note that a large number of objects received by the National Museum were not entered in the Accession Register for more than a year. The Committee are also surprised to learn that during the last 1½ years no inventory was maintained in which an article was entered as soon as it was received. The Committee consider that it was a very sad state of affairs. The Committee suggest that this may be remedied at once.
- 71 77 The Committee were told that some losses of objects received in the National Museum had been discovered and action was being taken to find out

1

2

3

whether they were actual losses. The Committee consider that this position is not satisfactory.

- 72 78 The Committee suggest that a catalogue of the collections of the National Museum should be maintained.
- 73 79 The Committee consider that it is desirable that proper facilities for research should be made available to research scholars as early as possible.
- 74 81 The Committee suggest that lectures both popular and scientific should be arranged by the National Museum, for the benefit of students and research scholars with prior arrangements with universities and other institutions interested in the subject. The Committee would like to emphasise the desirability of maintaining close co-ordination between the National and educational institutions as the Museum is one of the most important agencies of education.
- 75 82 The Committee suggest that it would be desirable to maintain co-ordination with foreign Museums in order to benefit from the latest Museum techniques and processes.
- 76 84 The Committee consider it as rather unfortunate that there were wide variations between the budget estimates and the actual expenditure of the National Museum during the last three years. The Committee stress the necessity of framing the budget estimates in a more realistic manner.
- 77 88 The Committee suggest that a catalogue of the books available in the library of the Central Asian Antiquities Museum may be printed and published for the benefit of scholars.
- 78 89 The Committee suggest that suitable arrangements should be made by the Central Asian Antiquities Museum for guiding research students.
- 79 90 The Committee suggest that lectures should be arranged by the Central Asian Antiquities Museum periodically in collaboration with the National Museum and the Delhi University.
- 80 91 The Committee suggest that necessary co-ordination between the Central Asian Antiquities Mu-

- seum and other Museums and Universities in re-
search in museology, may be maintained.
- 81 92 The Committee learn that only 5 employees of other
Museums received training in the Central Asian
Antiquities Museum during the last five years.
The Committee consider this as highly un-
satisfactory. They are of the opinion that
training facilities should be expanded and
better utilised.
- 82 93 The Committee suggest that the feasibility of having
a centralised agency for doing preservation work
of the various Government departments should be
examined. In the meantime, effective steps
should be taken to have greater co-ordination
between the various institutions like the National
Museum, National Archives of India and other
Museums, in regard to the work of preservation,
- 83 94 The Committee suggest that as soon as the first
phase of the development of the National Mu-
seum is completed, the Central Asian Antiquities
Museum should become part of the National Mu-
seum.
- 84 99 The Committee suggest that suitable steps may
be taken to exhibit the rich textile collections
of the Indian Museum, Calcutta.
- 85 99 The Committee suggest that the question of trans-
ferring the Indian Museum to the State Govern-
ment may be considered.
- 86 100 The Committee suggest that the decision of the
Government on the plan submitted by the
Trustees of the Indian Museum to the former
embodying their main needs *i.e.* (a) extra accom-
modation and building projects; (b) a unified con-
trol of the Indian Museum with all its sectional
laboratories and libraries and of the necessary
staff; (c) provision of modern techniques as em-
ployed in the Museums in progressive countries
for preservation, publicity and educational pro-
grammes; and (d) provision for gallery ex-
pansion *viz.*, Science Museum, Children's Mu-
seum, a big public hall may be expedited.
- 87 101 Pending final approval and implementation of the
Plan of Development suggested by the Trustees
of the Indian Museum, the Committee suggest
that the following important and immediate

problems of internal management should be attended to without delay:—

- (a) more accommodation;
- (b) more amenities for visitors;
- (c) better arrangements of the exhibits, and for explanations to visitors;
- (d) repairs of the exhibits, renovations and addition of new items and
- (e) publication of catalogues and other materials for the better service of the public.

- 88 102 The Committee understand that no definite proposals have so far been received by the Government of India from the State Governments for the development of Museums in their respective jurisdictions and that consequently, no substantial progress has been made in this direction. The Committee suggest that the question of revising the scheme of development of Museums of all-India character so that instead of the present 50:50 basis, the Centre might give 50% the, the State Governments 25% and other local organisations like the Universities, the local bodies, etc. 25% may be examined in order that the scheme may make a headway. The Committee also suggest that the scheme should include grants towards the expenses of trained staff in local museums. The Committee feel that the State Governments also should consider it their duty to encourage the development of museums by at least coming forward with their share of 25% if not 50% as was contemplated in the original scheme. The Committee further feel that the museums should not remain at the stage in which they were in the 19th century and that it is desirable that they make some progress with a concrete programme.
- 89 104 The Committee suggest that the National Gallery of Modern Art should be transferred to an autonomous or semi-autonomous body like the Lalit Kala Akadami or the Fine Arts Society.
- 90 106 The Committee suggest that some sort of exchange of objects or exhibitions by the National Gallery of Modern Art with other Galleries should be arranged so that people in other places would also benefit from them.

1

2

3

- 91 107 The Committee are glad to learn that monthly lectures are arranged by the National Gallery of Modern Art in New Delhi. The Committee suggest that similar lectures should be arranged also in other parts of the country.
- 92 108 The Committee suggest that necessary steps should be taken as early as possible to overcome the shortage of technical personnel in the National Gallery of Modern Art. In the meantime, frequent advice and guidance should be obtained from the preservation experts of the Museums and of the Archaeological Department, as well as of the National Archives.
- 93 109 The Committee understand that Jaipur House has not yet been purchased by the Government of India. The Committee suggest that before the proposal to air-condition the building is proceeded with, steps might be taken by the Government to purchase the building, if necessary.
- 94 113 The Committee recommend that the feasibility of all Librarians of Public and University libraries being trained in the National Library may be examined.
- 95 118 The Committee learn that the National Library is open all the days in the year except for three days (the Republic Day, the Independence Day and Mahatma Gandhi's Birthday). It is open from 9 A.M. till 8 P. M. on all days except on Sundays and holidays when it is open only from 10 A.M. to 5 P. M. The Committee suggest that similar facilities should be made available in other State Libraries also.
- 96 124 The Committee are well impressed with the way the National Library is being run. They would like all libraries in India to draw from the rich experience of the Library and recommend that ~~recommend that~~ Government should expand the facilities in the National Library for training, reference, lending etc. to serve this end. The Committee are of the opinion that it would be useful for the Librarians in charge of other big libraries in the country, to be deputed to spend a few weeks in the National Library, so that they may get familiarised with the modern techniques of library science.